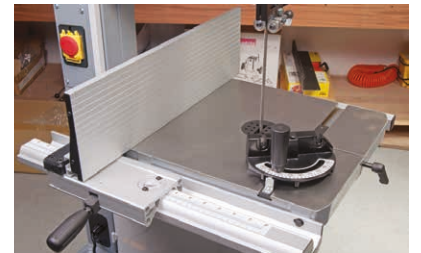



AT2552B Bandsaw



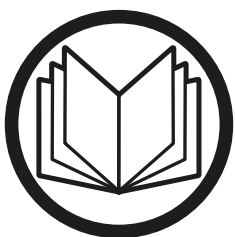
Index of Contents

EU Declaration of Conformity	02
What's Included	03-04-05
General Instructions for 230V Machines	06
Specification	07
Main Assembly	07-08-09-10-11-12-13-14
Machine Footprint	14
Illustration and Parts Description	15-16-17-18-19-20
Setting Up the Saw	21-22-23-24-25
Operating Instructions	26
Changing the Saw Blade	26-27
Maintenance	28
Exploded Diagrams/Lists	29-30-31-32-33-34
Wiring Diagram	35

EU Declaration of Conformity

<p>Cert No: SBW-3501B1</p> <p>Axminster Tools & Machinery Ltd Axminster Devon EX13 5PH UK axminster.co.uk</p> <p>declares that the machinery described:-</p> <table border="1"> <tr> <td>Type</td> <td>Bandsaw</td> </tr> <tr> <td>Model</td> <td>AT2552B</td> </tr> </table> <p>Signed </p> <p>Andrew Parkhouse Operations Director</p> <p>Date: 27/04/2015</p>	Type	Bandsaw	Model	AT2552B	<p>EU Declaration of Conformity</p> <p>This machine complies with the following directives:</p> <p>2006/42/EC 2006/95/EC 06/42/EC - Annex I/05.2006 EN 1807-1:2013</p> <p>conforms to the machinery example for which the EC Type-Examination Certificate No BM 50309398 001, 11017557 005, 11017557 002, 11018146 001, 110181146 002 has been issued by TÜV Rheinland Taiwan Ltd at: 11F., No. 758, Sec. 4, Bade Rd., Songshan Dist., Taipei City 105, Taiwan R.O.C.</p> <p>and complies with the relevant essential health and safety requirements.</p>
Type	Bandsaw				
Model	AT2552B				

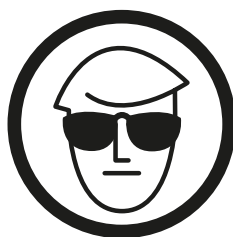
The symbols below advise the correct safety procedures when using this machine.



Fully read manual and safety instructions before use



Ear protection should be worn



Eye protection should be worn



Dust mask should be worn



HAZARD

What's Included

Quantity	Item	Model Number			
		AT2552B			
1	Bandsaw				
	Bandsaw Blade 2552,mm (100.1/2") long, mounted on saw but not tensioned.				
1	Cast Iron Table	1			
Stand Assembly:					
2	Stand Supports	2			
2	Stand Support Brackets	3			
Fence Assembly:		Bags Comprising:			
1	Front Fence Rail with Scale	4	1	Mitre Fence	17
1	Rear Fence Guide Rail	5	2	Clamping knobs with	
1	Fence	6		M8 threads	18
1	Fence Clamp Assembly with		1	M8 x 80mm Bolt & M8 Nut	19
	Magnifying Glass	7	8	M6 Flat Washers	20
1	M8 Lift and Shift Handle	8	2	M4 Nuts	21
1	M8 Threaded Lever	9	8	M6 Shoulder Nuts	22
1	Threaded 'T' Slot Insert	10	8	M8 Shoulder Nuts	23
2	M6 x 20mm Threaded Bolts	11	2	Domed Head Phillips Screws	24
2	M6 x 16mm Caphead Bolts	12	8	M6 x 16mm Bolts	25
1	M8 Large Washer	13	8	M8 Coach Bolts	26
2	M6 Small Washers	14			
2	Spring Washers	15			
1	M8 Nut	16			
1	User Manual				



Please read the Instruction Manual prior to using your new machine; as well as the operating procedures for your new machine, there are numerous hints and tips to help you to use the machine safely and to maintain its efficiency and prolong its life. Keep this Instruction Manual readily accessible for any others who may also be required to use the machine.



1



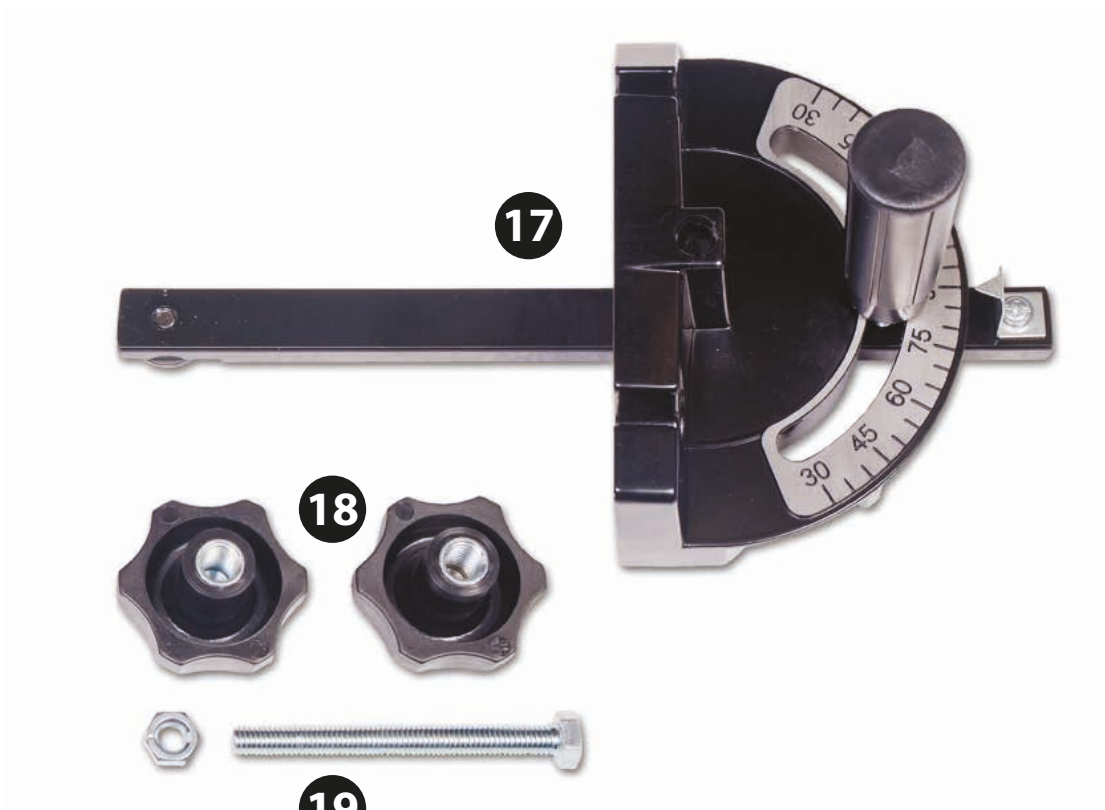
3

What's Included





8 9 10



20 21 22 23 24 25 26

General Instructions for 230V Machines

The following will enable you to observe good working practices, keep yourself and fellow workers safe and maintain your tools and equipment in good working order.



WARNING!! KEEP TOOLS AND EQUIPMENT OUT OF REACH OF YOUNG CHILDREN



KEEP WORK AREA AS UNCLUTTERED AS IS PRACTICAL. UNDER NO CIRCUMSTANCES SHOULD CHILDREN BE ALLOWED IN WORK AREAS.

Mains Powered Tools

- Tools are supplied with an attached 13 Amp plug.
- Inspect the cable and plug to ensure that neither are damaged. Repair if necessary by a suitably qualified person.
- Do not use when or where it is liable to get wet.

Workplace

- Do not use 230V a.c. powered tools anywhere within a site area that is flooded.
- Keep machine clean.
- Leave machine unplugged until work is about to commence.
- Always disconnect by pulling on the plug body and not the cable.

- Carry out a final check e.g. check the cutting tool is securely tightened in the machine and the correct speed and function set.
- Ensure you are comfortable before you start work, balanced, not reaching etc.
- Wear appropriate safety clothing, goggles, gloves, masks etc. Wear ear defenders at all times.
- If you have long hair wear a hair net or helmet to prevent it being caught up in the rotating parts of the machine.
- Consideration should be given to the removal of rings and wristwatches.
- Consideration should also be given to non-slip footwear etc.
- If another person is to use the machine, ensure they are suitably qualified to use it.
- Do not use the machine if you are tired or distracted
- Do not use this machine within the designated safety areas of flammable liquid stores or in areas where there may be volatile gases.
- Check cutters are correct type and size, are undamaged and are kept clean and sharp, this will maintain their operating performance and lessen the loading on the machine.
- **OBSERVE....** make sure you know what is happening around you and **USE YOUR COMMON SENSE.**

Specification

Code	105096
Model	AT2552B
Rating	Trade
Power	550W 230V 50Hz 1ph
Blade Speed	800m/min
Blade Length	2,552mm(100.1/2")
Blade Width Min/Max	3mm(1/8")/19mm(3/4")
Max Width of Cut	340mm
Max Depth of Cut	200mm
Max Width of Cut with Fence	300mm
Table Size	500 x 356mm
Table Height on Stand	1,060mm
Table Tilt	-5° to +45°
Table Height	490mm
Wheel Diameter	350mm
Dust Extraction Outlet	100mm
Overall L x W x H	690 x 720 x 1,770mm
Weight	84kg

Main Assembly

Your bandsaw is 90% assembled in order to reduce the footprint of the machine for packaging, several items are dismantled from the machine and need to be re-affixed.



HAVING UNPACKED YOUR ACCESSORIES PLEASE DISPOSE OF ANY UNWANTED PACKAGING PROPERLY. THE POLYTHENE AND CARD IS RECYCLABLE.



WARNING! THE BANDSAW IS A HEAVY PIECE OF MACHINERY, WE STRONGLY ADVISE YOU GET THE ASSISTANCE OF ANOTHER PERSON OR USE SOME SORT OF LIFTING DEVICE, (HOIST, ENGINE CRANE), BEFORE YOU ATTEMPT TO LIFT OR MOVE THIS MACHINE!

Stand Assembly

You will require the stand supports (02), stand support brackets (03), M6 bolts (25), M6 shoulder nuts (22) and M6 flat washers (20), see fig 01.

Step 1 Line up the first two pre-drilled holes in the support bracket (03) with the holes to one side of the support stand (02) and secure using the M6 bolts, washers and nuts (20-22-25), see fig 2. Repeat for the remaining stand and bracket.

NOTE: Make sure the support brackets (03) are the correct way round, otherwise the remaining holes in the stand assembly will not line up.

Fig 01

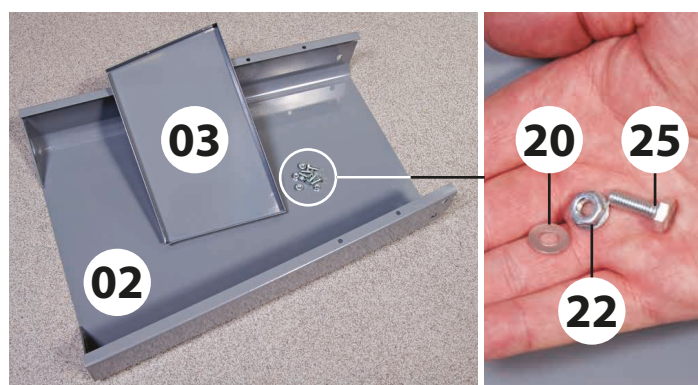


Fig 02



Main Assembly

Step 2 Line up the remaining holes in the two parts of the assembly and secure using the remaining M6 bolts, washers and nuts (20-22-25), securely tighten all fixing, see figs 03-04.

Fig 03



Fig 04



Fig 05



Mounting the Bandsaw



WARNING!! WHEN MOUNTING THE UNIT, WE STRONGLY ADVISE YOU GET THE ASSISTANCE OF ANOTHER PERSON BECAUSE THE BANDSAW IS HEAVY .

Lift the saw on to the stand and line up the pre-drilled holes, see fig 05, secure using the eight M8 coach bolts (26) and M8 shoulder nuts (23), see fig 06.

Fig 06



Mounting the Emergency Stop Assembly

Step 1 Locate the two domed head Phillips screws (24) and M4 nuts (21), see fig 07. loosen the four Phillips screws from the front of the emergency stop housing and very carefully open the outer cover, see fig 08.

Fig 07



Fig 08



Step 2 Line up the two elongated holes in the rear of the emergency stop housing with the two pre-drilled holes to the front of stand, insert one of the domed Phillips screw through the housing and while holding it in place screw on the M4 nut (21) and finger tighten. Repeat for the opposite side then fully tighten the fixings, see figs 09-10-11.

Step 3 Carefully replace the outer housing and tighten the four Phillips screws, see fig 12.

Fig 09-10-11-12

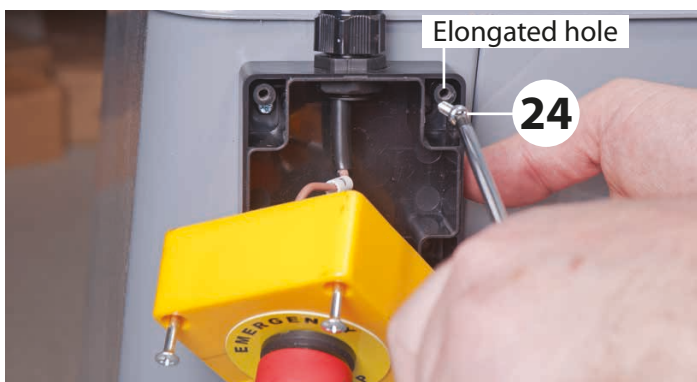
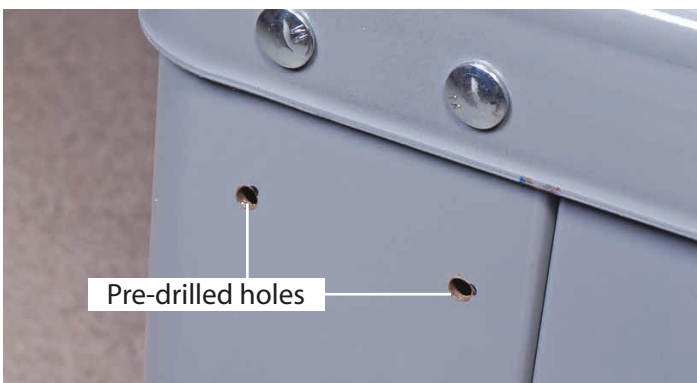
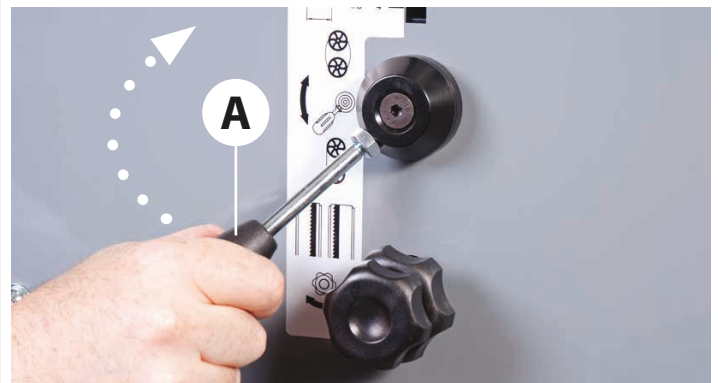


Fig 13-14



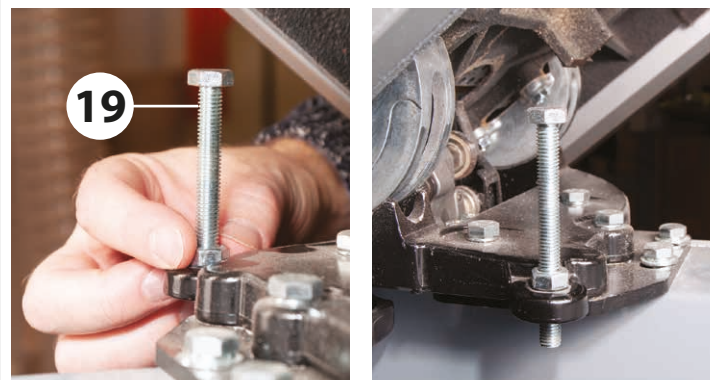
Mounting the Table

The saw table can be fitted without removing the blade. However, if you would feel more comfortable not having to manoeuvre the table around the blade (the table is quite heavy), remove the blade by opening the top and bottom covers, release the tension on the blade by releasing the Quick release tensioning lever (A), see fig 13-14.

Locate the cast iron table (1) the two M8, clamping knobs (18) and M8 x 80mm Bolt and Nut (19).

Step 1 Locate the threaded bolt/nut (19), screw the nut onto the thread then screw the bolt into the pre-drilled hole in the bandsaw tilt quadrant, see fig 15.

Fig 15



Main Assembly

Step 2 Remove the table insert and table alignment pin and place safely aside, see figs 16-17. Lift the table (1), slide the blade through the table slot, see fig 18, line up the two threaded bolts to the underside of the table and lower them through the holes in the tilt quadrant assembly, see fig 19.

Make sure the table is seated correctly on the tilt quadrant then screw on the two clamping knobs (18) to clamp the table (1) in position, see fig 20.

Fig 16-17

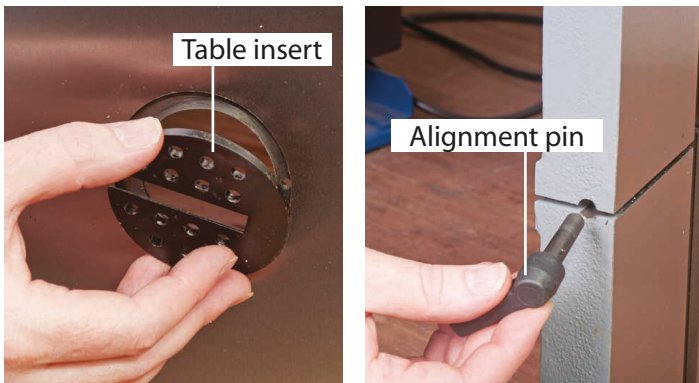


Fig 18



Fig 19

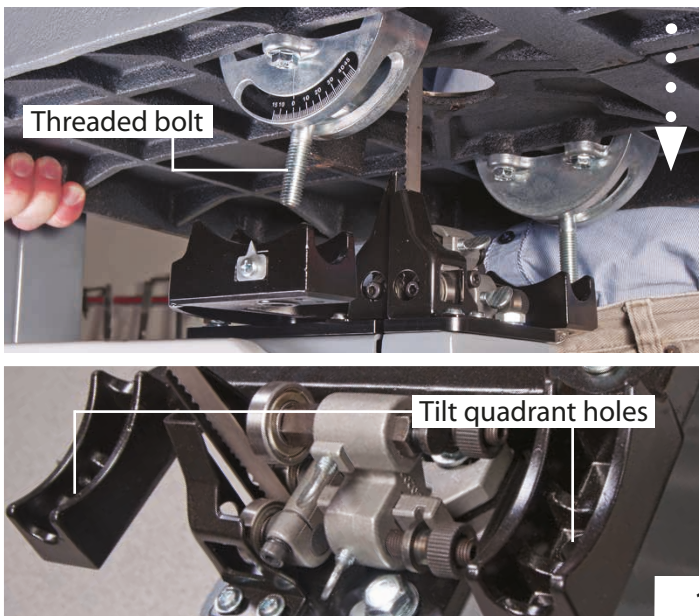
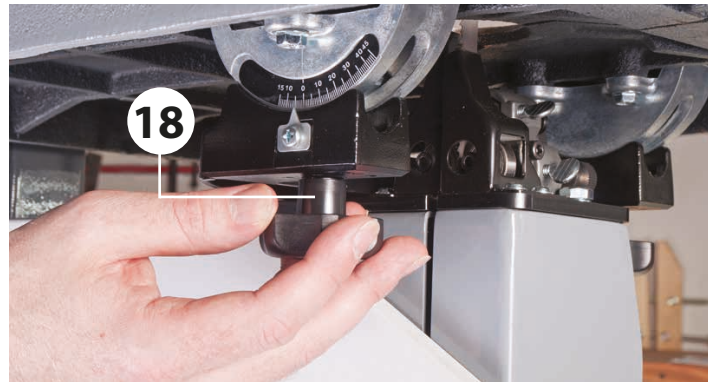
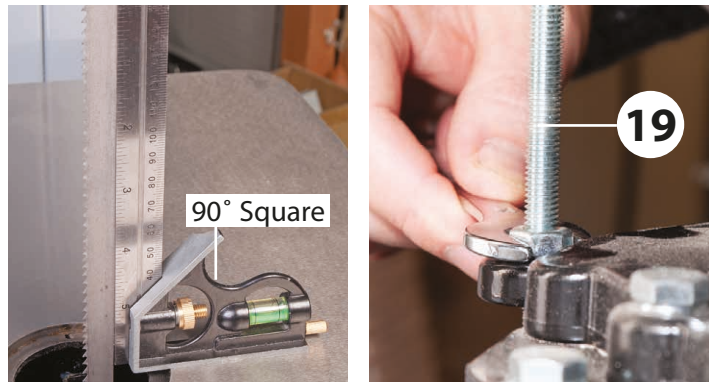


Fig 20



Step 3 Place a 90° square up against the blade, loosen the tilt quadrant clamping handles (18) and adjust the table levelling stop bolt (19) beneath the table until the table is perpendicular to the blade. Nip tighten the nut on the stop to lock the setting, see figs 21-22. Retighten the clamping knobs (18).

Fig 21-22



Step 4 Locate the table alignment pin you removed earlier, place a straight edge or 90° square across the table's slot and introduce the tapered alignment pin into the tapered hole to the front of the table, this will align both sides of the table, see figs 23-24.

Fig 23

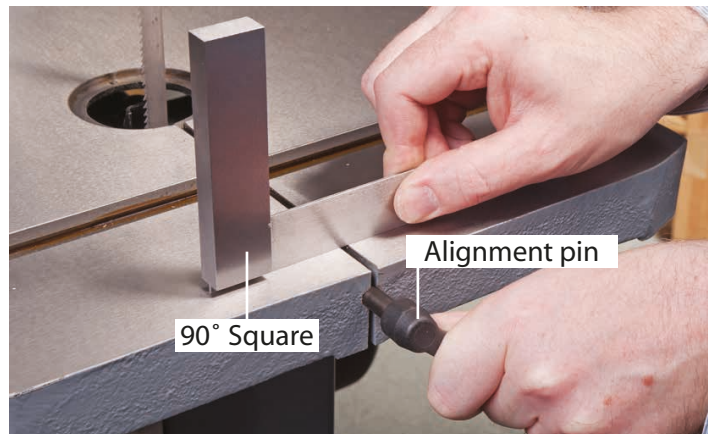


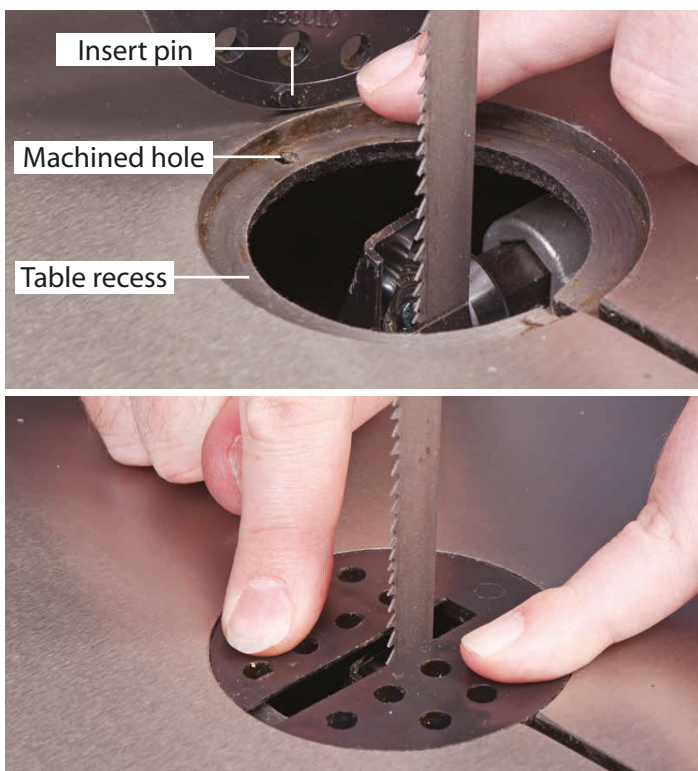
Fig 24



Checking both sides of the table are level

Step 5 Replace the table insert by lining up the two pins in the insert with the machined holes in the recess to the centre of the cast iron table. Push firmly down, see figs 25-26.

Fig 25-26

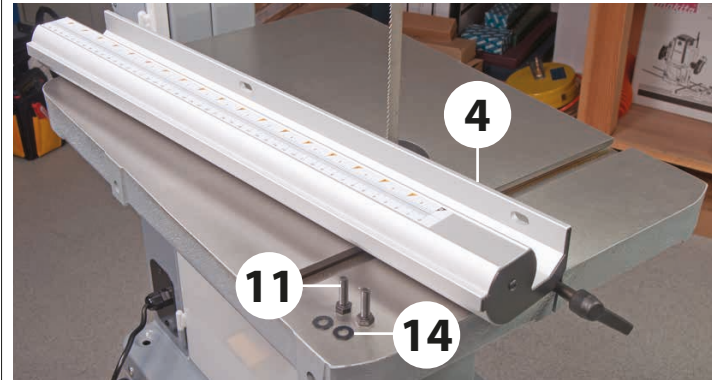


Fence Assembly

Locate the front fence rail with scale (4), rear fence guide rail (5), fence (6), fence clamp assembly (7), M8 lift & shift handle (8), M8 threaded lever (9), threaded 'T' slot insert (10), M6x20mm bolts (11), M6x16mm bolts (12), M8 large washer (13), M6 small washers (14), spring washers (15) and M8 nut (16).

Step 1 Place a washer (14) over each M6x20mm bolt (12), line up the elongated holes in the front fence rail (4) with the pre-drilled holes to the front of the cast iron table (1), introduce the two M6x20mm bolts (12) through the fence rail and lightly tighten using the supplied spanner (22), see figs 27-28-29-30.

Fig27-28-29-30



Step 2 Place a spring washer (15) over each M6 caphead screw (12), line up the holes in the rear fence guide rail (5) with the threaded holes to the opposite side of the cast iron table and secure in place with the two M6 caphead screws (12) and using a 5mm Hex key tighten the guide rail, see figs 31-32-33-34.

Fig 31

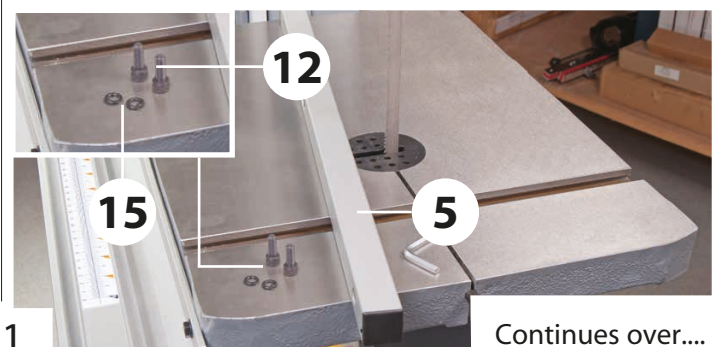


Fig 32-33-34



Step 3 Fit the fence clamp assembly (7) over the front fence rail (4) and lower the rear of the clamp assembly so the adjustable guide rests on top of the rear guide rail (5), see fig 35-36.

Fig 35

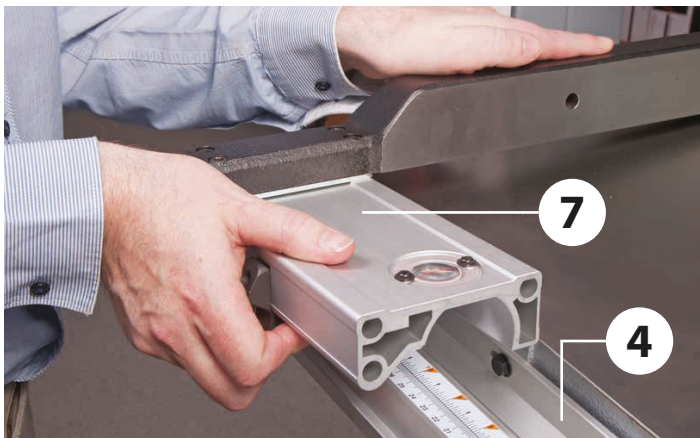
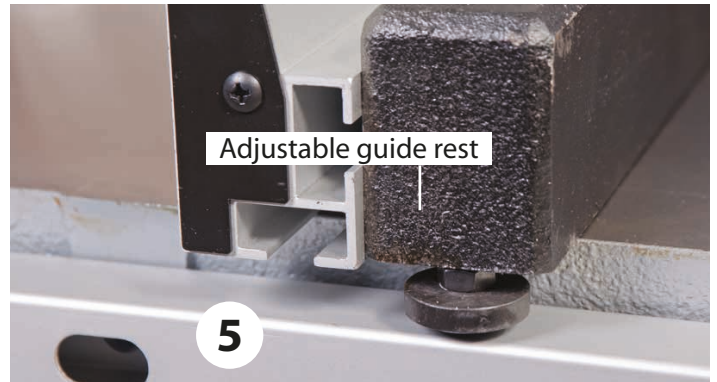


Fig 36



Step 4 Locate the M8 nut (16), and screw it onto the thread of the M8 threaded lever (9) then screw the threaded lever (9) into the threaded hole in the clamp assembly (7) mechanism and tighten the nut with a spanner, see figs 37-38.

Fig 37-38



Step 5 Slide the fence assembly (7) until it's up against the blade and press down the locking lever (9), see fig 39. Look at the 'RED' line on the magnifying glass to check it's set to '0' on the scale, see fig 40. If it's out of alignment, loosen the front fence rail (4) and tap the side of the fence until the scale reads '0' then re-secure the fence rail, see figs 41-42.

Fig 39

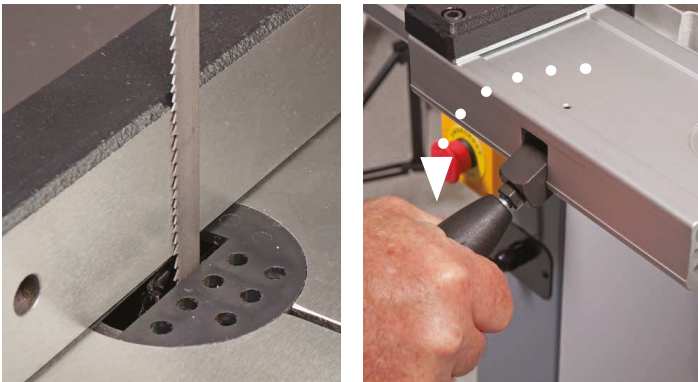
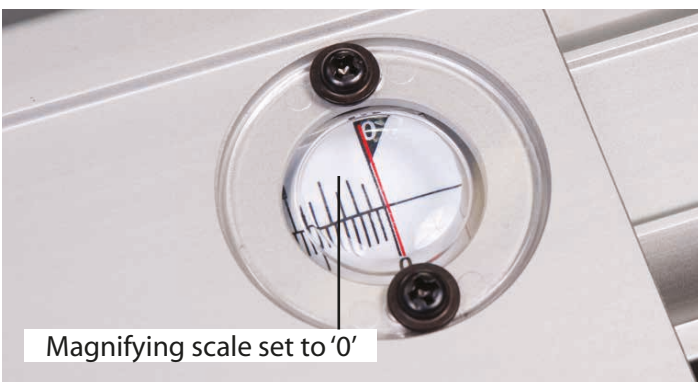


Fig 40-41-42



Step 6 Locate the fence (6), M8 lift and shift handle (8), M8 large washer (13) and threaded 'T' slot insert (10), see fig 43. Place the large washer over the thread of the lift and shift handle (8), see fig 44, introduce the handle through the machined hole to the side of the cast iron fence (7) and lightly screw on the threaded 'T' slot insert (10), see fig 45.

Fig 43

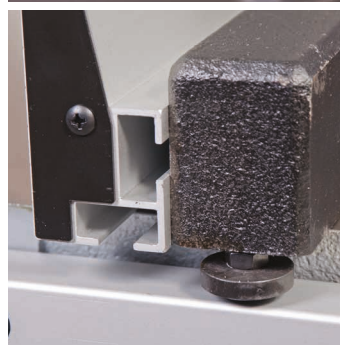


Fig 44-45



Step 7 Introduce the 'T' slot to the side of the fence (6) over the threaded 'T' slot insert (10) and slide on the fence until the fence (6) is flush with the end of the cast iron fence (7). Tighten the lift and shift handle (8), see figs 46-47-48.

Fig 46-47-48



Main Assembly/Machine Footprint

NOTE: The fence (6) has two positions, vertical and horizontal for cutting narrow pieces, see fig 49-50-51.

Fig 49-50-51



Mitre Fence Assembly

Locate the mitre fence (19) and slide the mitre fence into the table (1) 'T' slot, see fig 52.

Fig 52

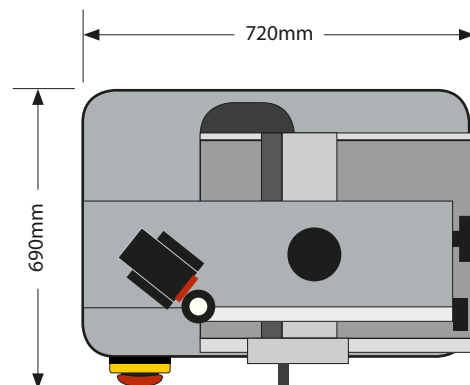
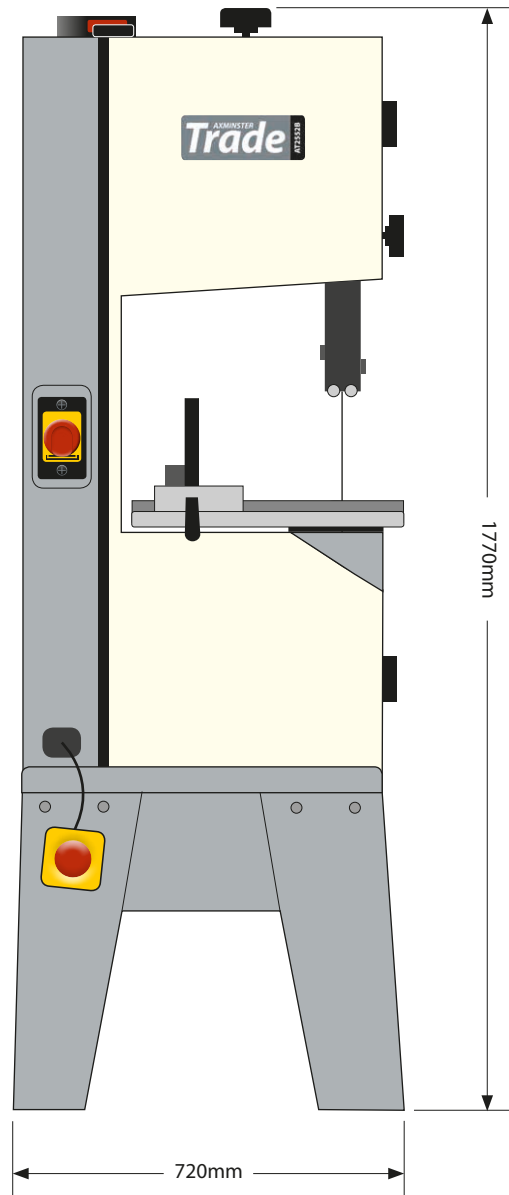


Illustration and Parts Description

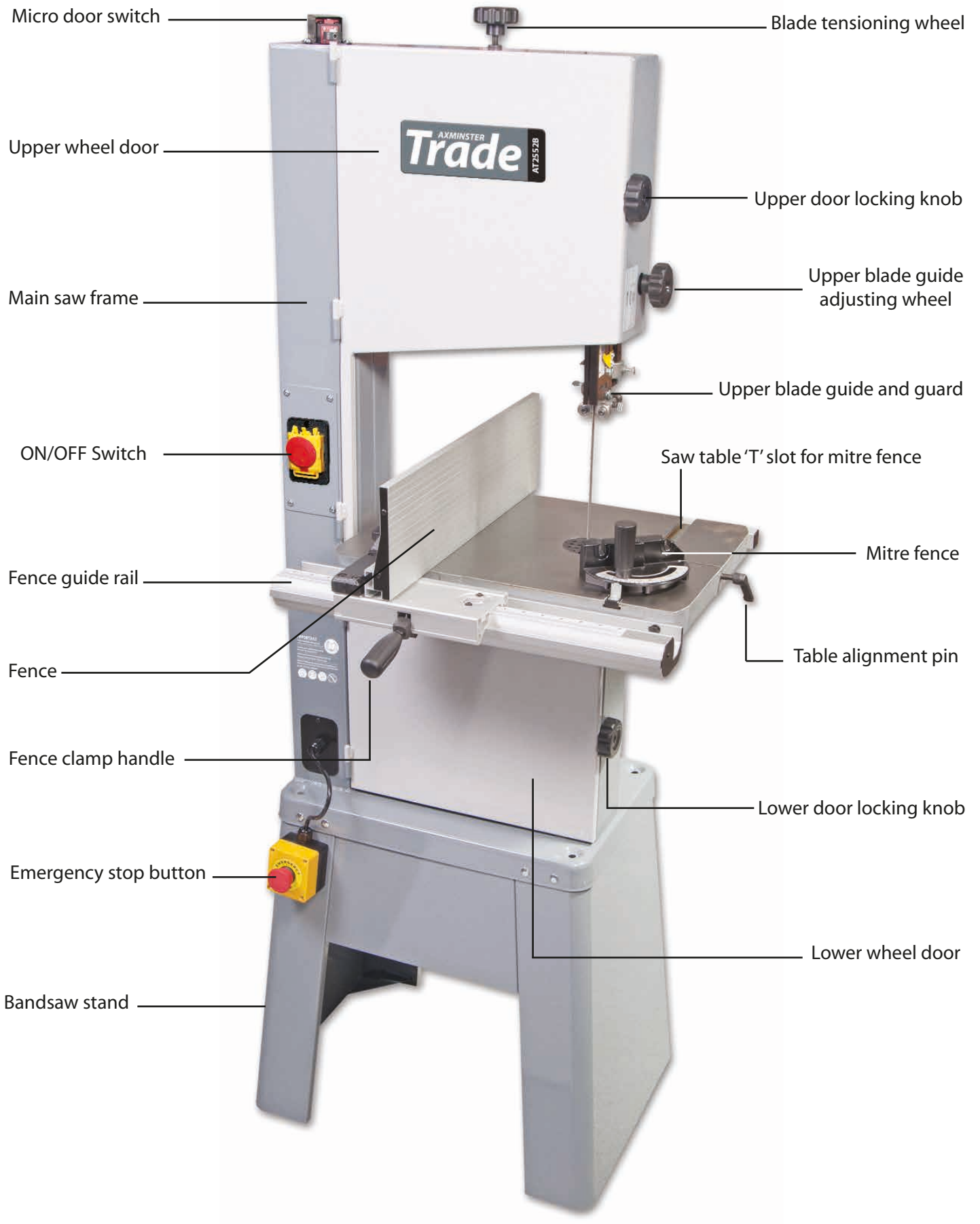


Illustration and Parts Description



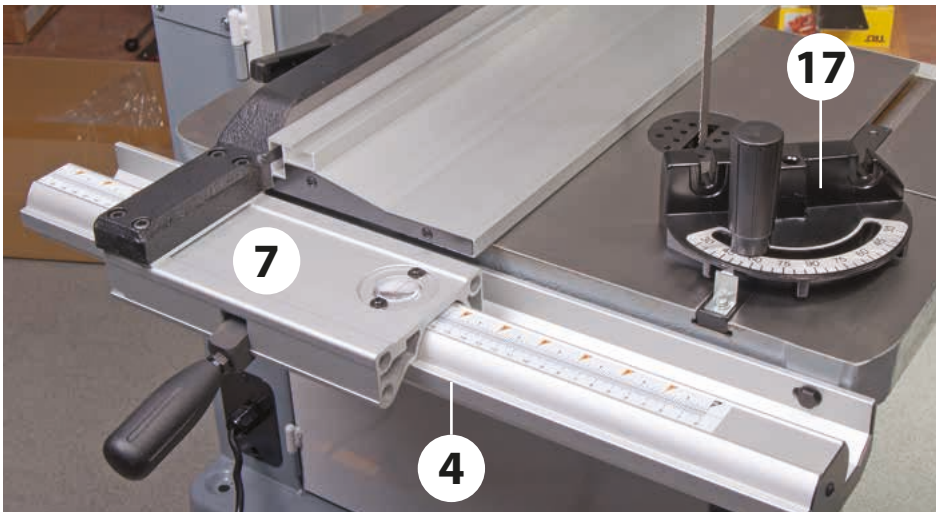
Emergency stop, press to stop the bandsaw



On/Off Switch with Emergency Stop Shroud



Upper door micro switch assembly



Fence clamp assembly (7), Mitre fence (17), Fence rail with scale (4)



Scale magnifying glass Upper blade guide height scale and pointer



Upper blade guide height scale and pointer



Table levelling stop bolt



Table insert

Illustration and Parts Description

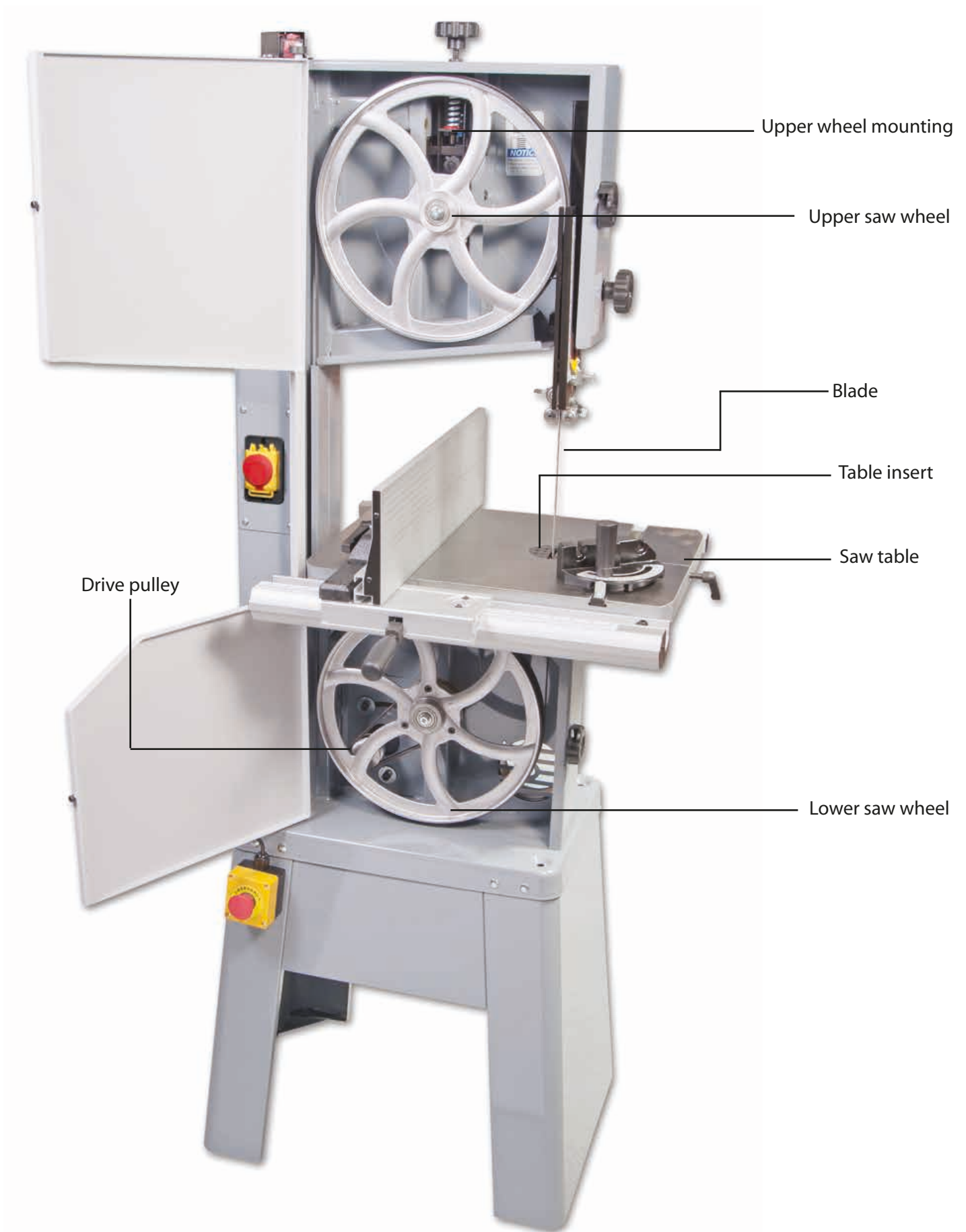
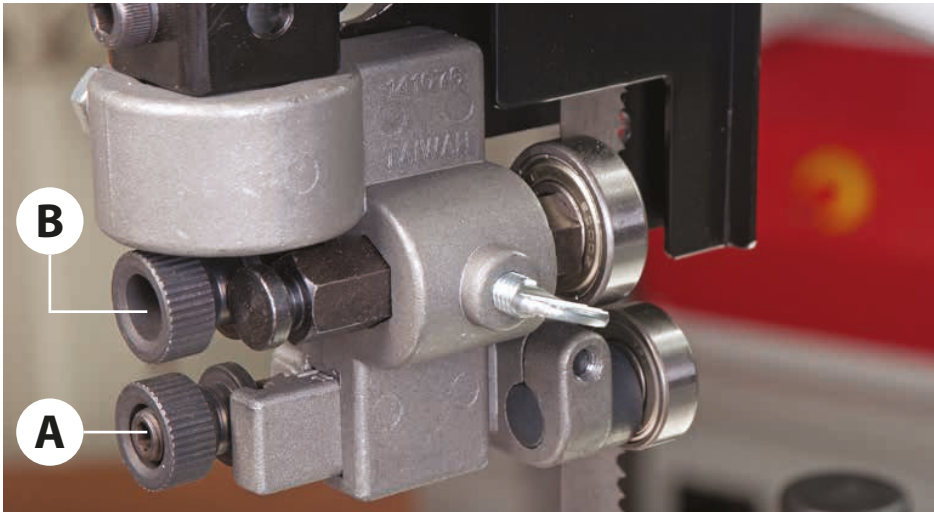
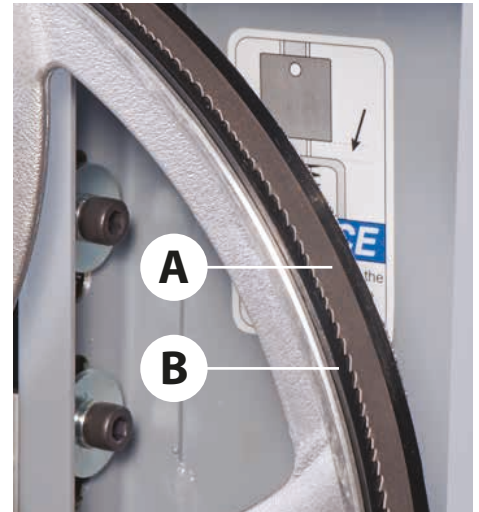


Illustration and Parts Description



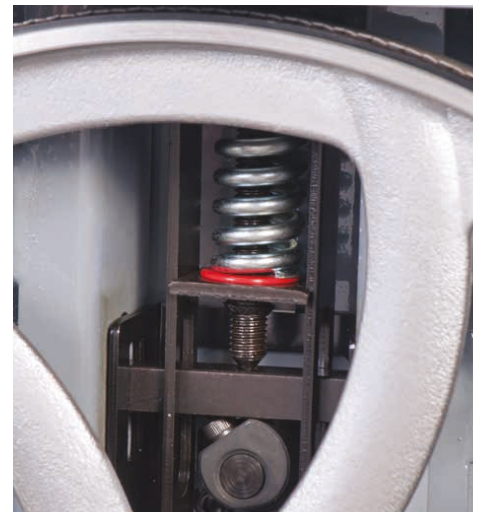
Blade guide fore and aft adjusting knob (A), Rear thrust bearing adjusting knob (B)



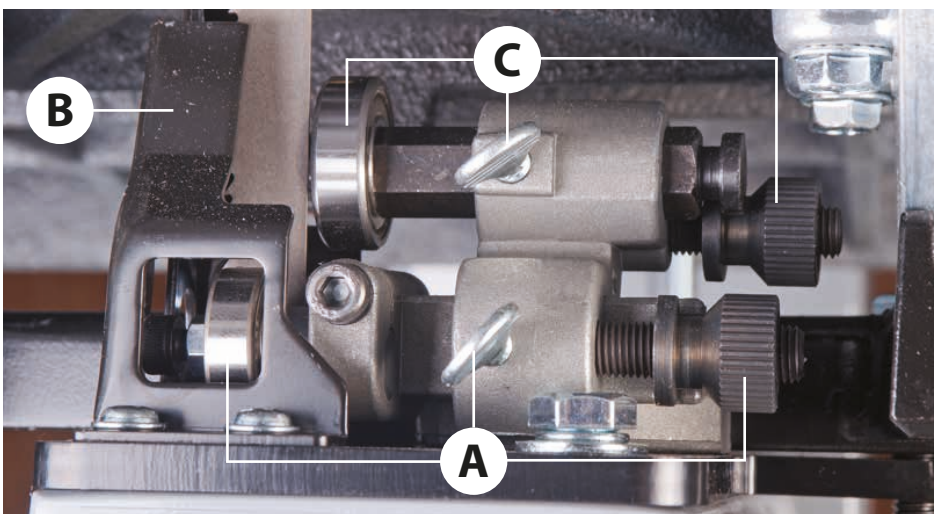
Blade (A), Tyre (B)



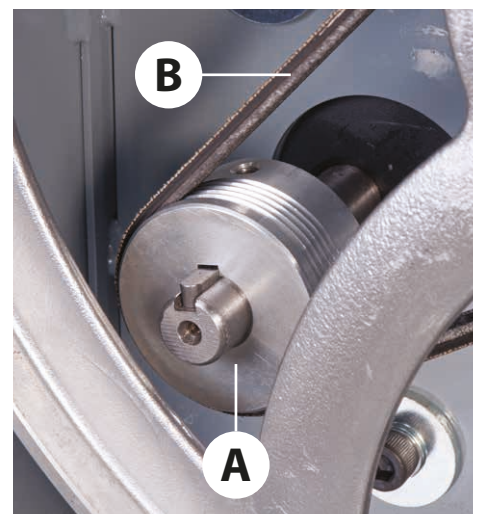
Upper bearing blade guides (A), Rear thrust bearing (B) and rear thrust bearing butterfly clamping screw (C)



Blade tensioning mechanism



Lower bearing blade guide, butterfly clamp and adjusting knob (A), lower bearings guide guard (B) Rear thrust bearing, butterfly clamp and adjusting knob (C)



Drive pulley (A), Pulley belt (B)

Illustration and Parts Description

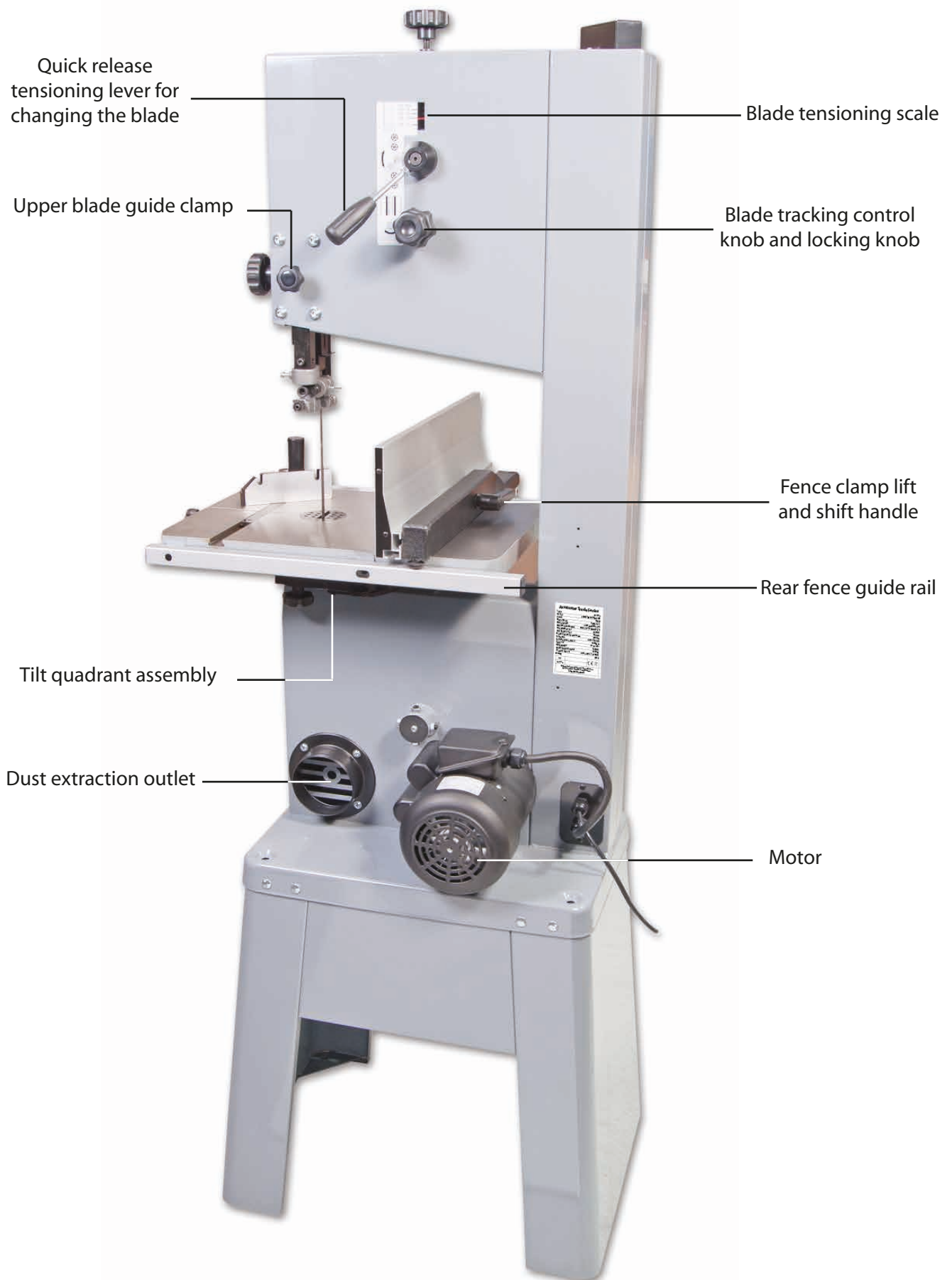
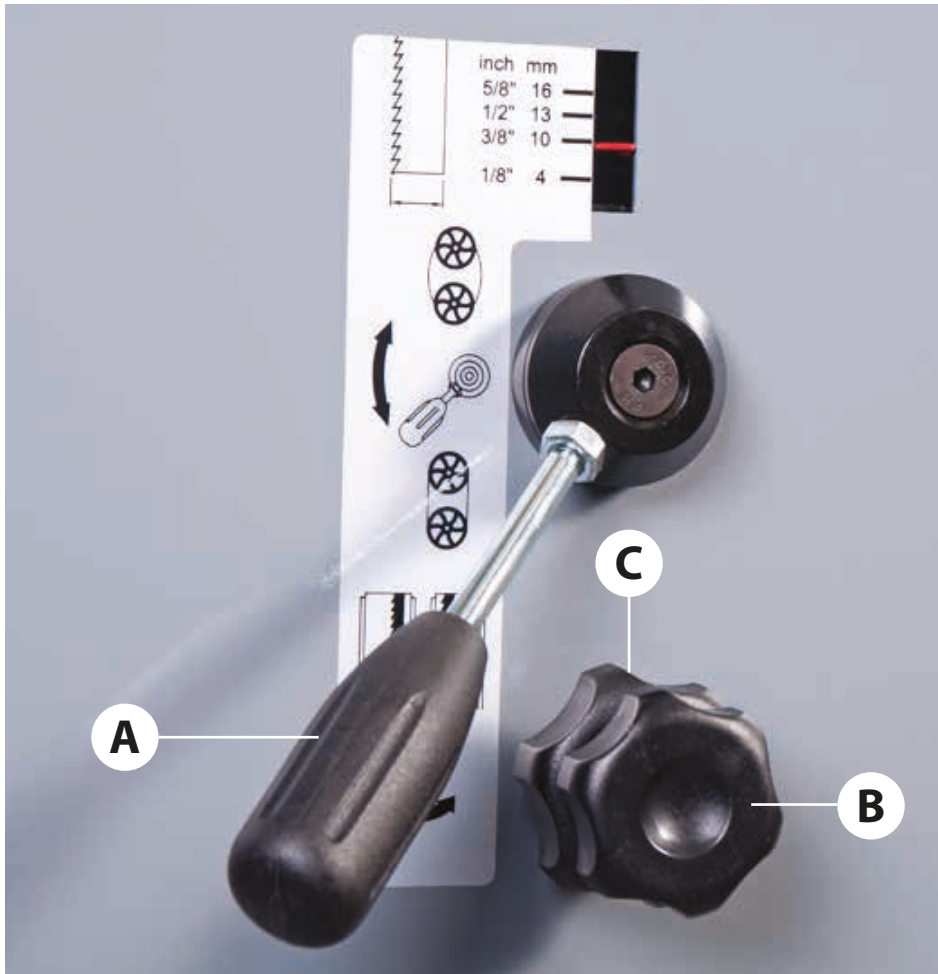
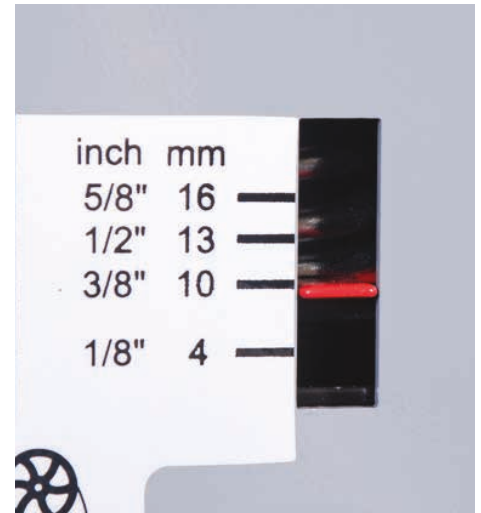


Illustration and Parts Description



Quick release tensioning blade lever (A), Tracking control knob (B) and locking knob (C)



Blade tensioning scale



Upper blade guide clamp

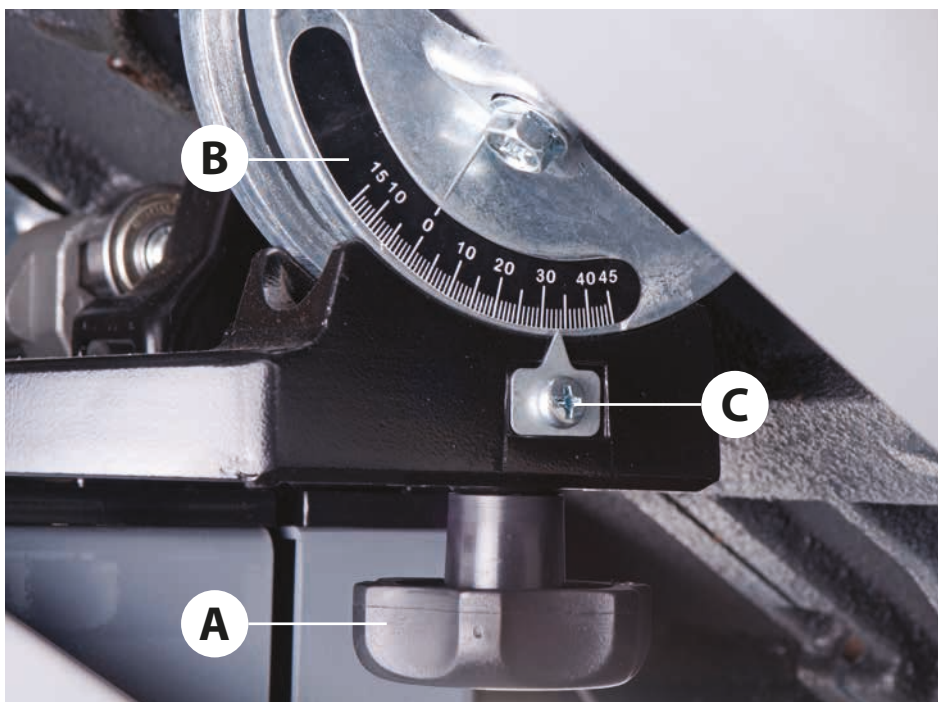


Table tilt clamping knob (A), Table tilt scale (B) and pointer with adjustment screw (C)



Dust extraction outlet



DISCONNECT THE SAW FROM THE MAINS SUPPLY!

Tensioning and tracking the blade

Make sure both top and bottom blade guides are well clear of the blade

Open the front covers fully, giving good access to the top compartment of the saw and good visibility into the bottom compartment (see page 17). For tracking the blade first adjust all bearing guides so that they're well clear of the blade. Check that the blade is sitting approximately in the middle of the wheels, see fig 53. Apply some tension to the blade by turning the tensioning wheel clockwise, see fig 54 spin the top wheel by hand and check that the blade remains centrally on the tyre, see fig 55. If it does not, adjust the tracking by turning the tracking control at the rear of the head box, see fig 56. Viewed directly onto the tracking control wheel, turning clockwise should cause the blade to track to the rear of the tyre; anti-clockwise to the front, DO NOT make large adjustments).

Spin the top wheel again, check again. Continue until the blade tracks in the centre of the tyres with no appreciable to and fro movement. Tighten the tracking control knob to lock the setting. Tension the blade fully. A sideways push of about 7-8 lbs(3+kgs) in the middle of the blade should allow a 1/4" (6.5mm)distension. Check the tracking again, adjust if necessary. Check that the drive belt is tensioned correctly. If it is slack, apply 'take up' pressure to the belt by loosening the motor locking Hex bolt (A) and pushing down the motor assembly until the belt is under tension then re-tighten the Hex bolt to lock the motor in position, see fig 57-58.

Connect the power to the machine. Stand clear and start the saw. Check that the saw is running smoothly, (no thumps, bumps, knocking or excessive vibration) and the blade appears to be tracking correctly (in one place). You can check this by holding a marker, e.g. a pencil, close to the back of the blade (approach from the back of the blade only) and check that the gap remains constant.

If it doesn't, adjust the tracking until it does. Make very small adjustments and wait for the saw to react before you adjust again, sometimes the reaction is not instantaneous. Once you are satisfied that the tracking is correct, switch the machine off and allow it to run to a complete stop.

Fig 53



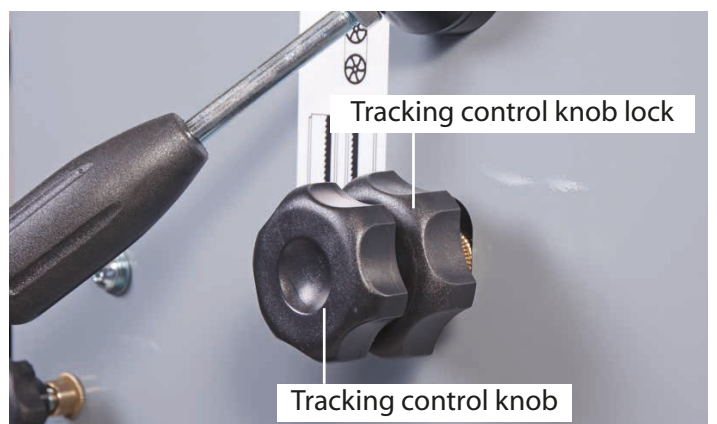
Fig 54



Fig 55

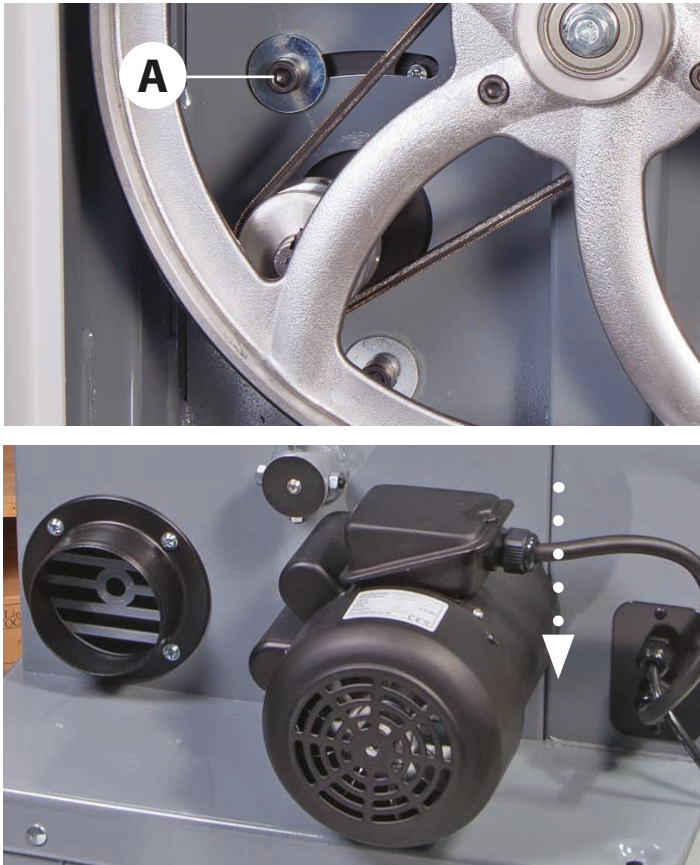


Fig56



Setting Up the Saw

Fig 57-58



Make sure the upper blade guide is raised as high as possible. Place a square on the table and move it up against the blade (behind the teeth), see fig 60.

Check that the blade is perpendicular to the table. If it is not, try resetting the table. If it is still not correct, loosen the table locking knobs, see figs 61 and adjust the table stop bolt nut until perpendicularity is achieved, see fig 62

Fig 60

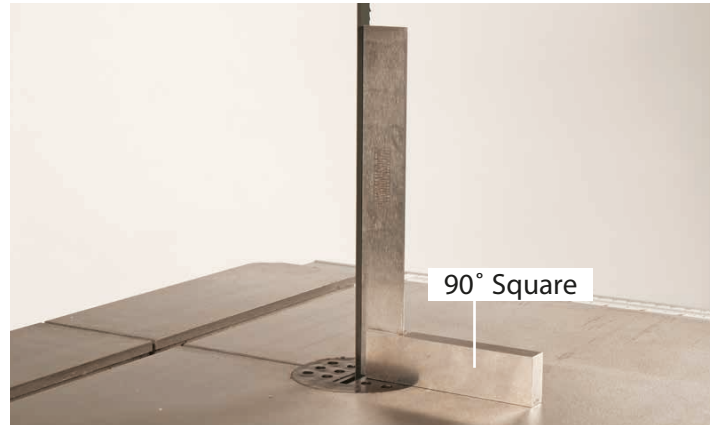
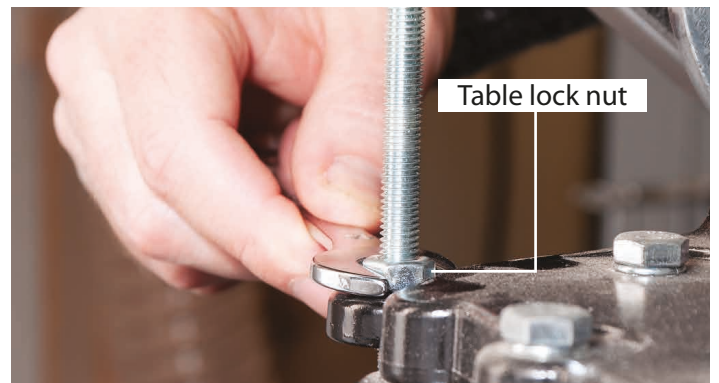


Fig 61



Fig 62



Tighten the lock nut and then re-check. When you are satisfied that the table is set correctly, check that the pointer of the tilt scale reads zero, if not, adjust it, see fig 63. Retighten the table clamping knobs.



DISCONNECT THE SAW FROM THE MAINS SUPPLY!

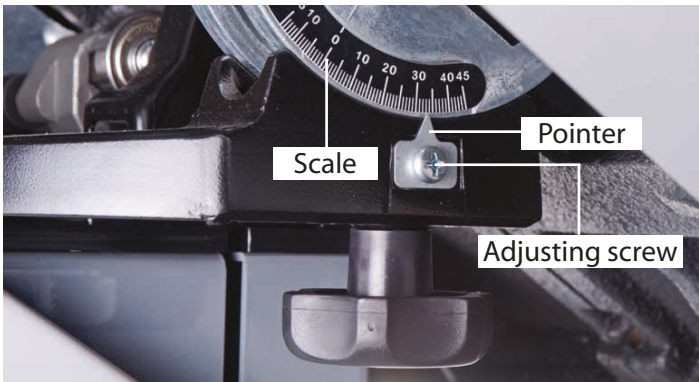
Checking the table is square

Loosen the two clamping knobs beneath the table, clamping the tilt mechanism. Lower the table until its against the stop (19). This is a bolt with a lock nut screwed into the underside of the table, see fig 59. The head of the bolt acts as a stop when it strikes the machine frame. Tighten the clamping knobs.

Fig 59



Fig 63



Setting the Fence

To make sure the guide fence is at 90° to the table, line up the guide fence with the edge of the table's 'T' slot, see fig 64. If you find that the fence is out of alignment follow the steps below:

- 1 Clamp down the fence by pushing the locking lever down, see fig 65.
- 2 Loosen the 4 Hex bolts that secures the fence and adjust until the fence is in alignment with the 'T' slot in the table, then re-tighten the bolts, see fig 66.
- 3 Replace the fence assembly to its original position.

Fig 64

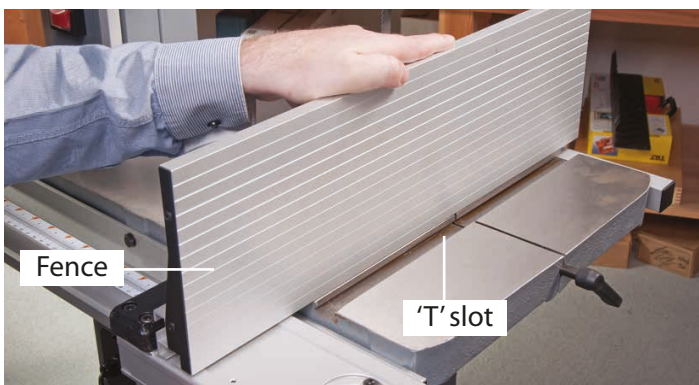
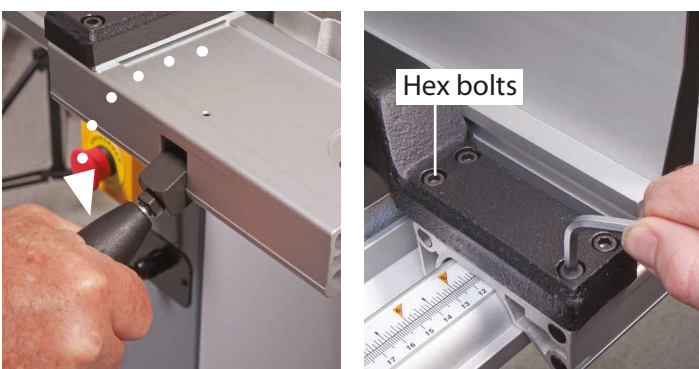


Fig 65-66



Setting the Blade Guides (above table)



DISCONNECT THE SAW FROM THE MAINS SUPPLY!

Lower the upper blade guide to approximately 1 1/2" (38mm) above the table. Clamp in place. Loosen the butterfly screw (A), holding the guide assembly in place and adjust the fore and aft position by turning the adjustment knob (B) so that the leading edges of the side guide bearings are approximately 2 mm behind the gullets of the saw blade. Re-tighten the butterfly screw, see fig 67-68. Loosen the butterfly screw (C) that clamps the rear thrust bearing in position and turning the adjustment knob (D) until the thrust bearing is approximately 1mm behind the blade, re-tighten the butterfly screw, see fig 69-71.

Fig 67-68

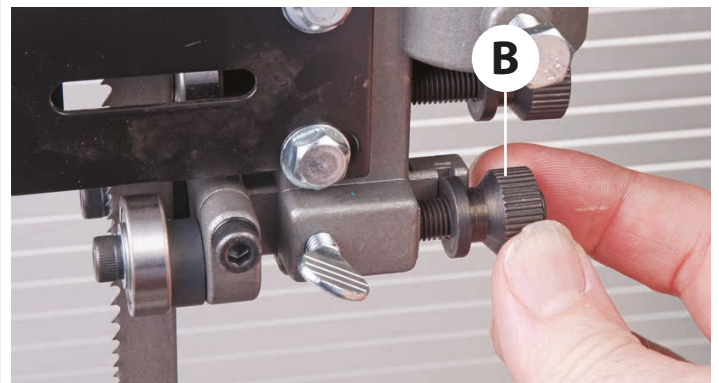
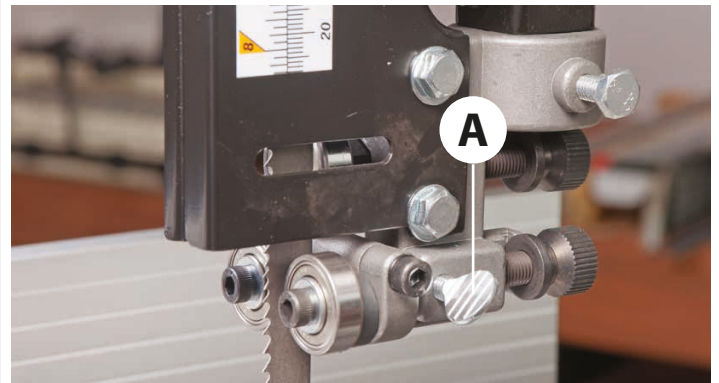
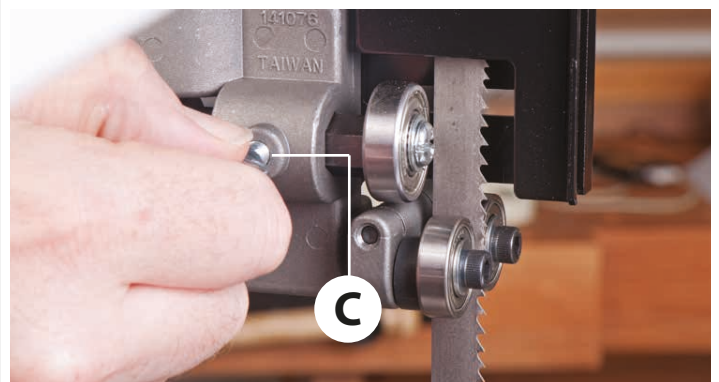
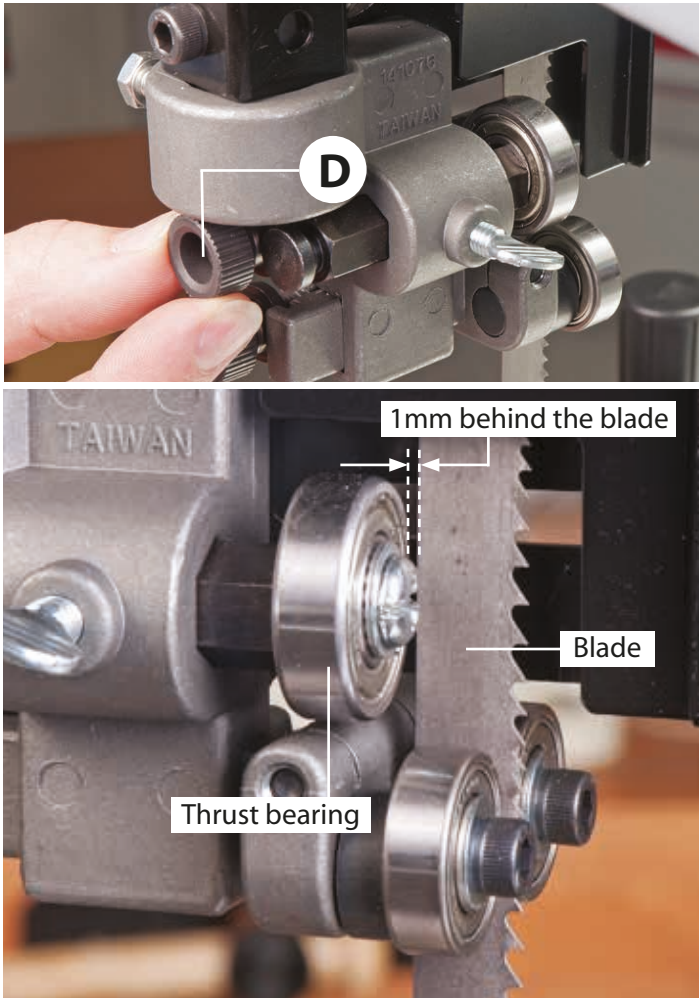


Fig 69



Setting Up the Saw

Fig 70-71



Loosen the Hex screw (A) holding the guide bearings and move to approximately 0.5mm from each side of the blade. **NOTE: A sheet of A4 of photocopier paper is approximately 0.5mm thick.** Adjust the guide bearings by turning the adjusting Hex screw (B), until the bearings are set to the correct thickness. Re-tighten the Hex screw (A), see fig 72-73-74.

Gently push the blade back against the thrust bearing, use a scrap of wood and check that the side bearings are still behind the teeth of the blade.

Fig 72

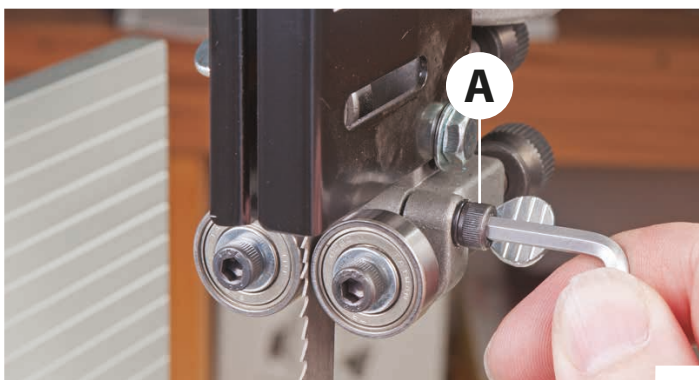
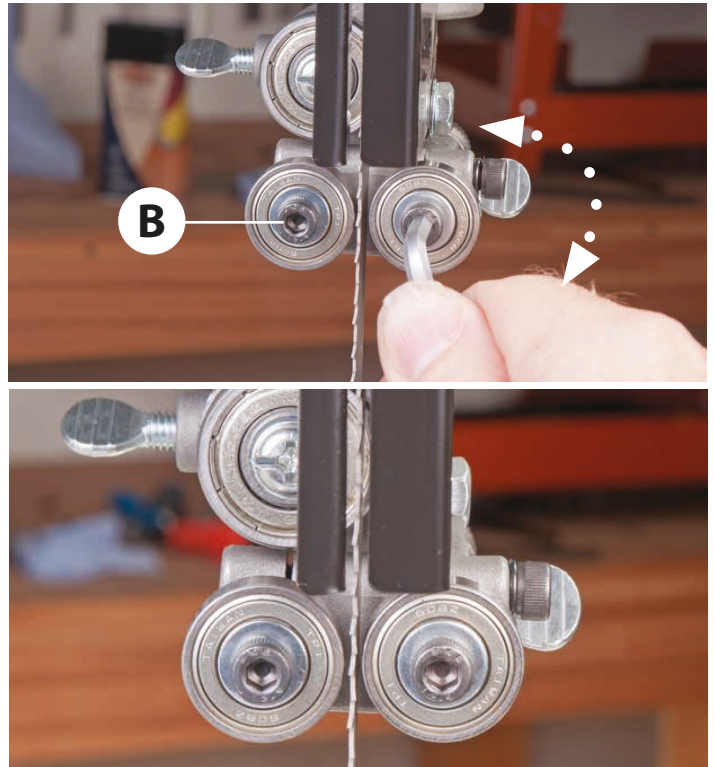


Fig 73-74



Guide bearings set to 0.5 thickness to the blade

Setting the Blade Guides (below table)



IT MAY BE EASIER TO SET THE GUIDE BEARINGS IF THE CAST IRON TABLE (1) IS REMOVED, REFER TO MAIN ASSEMBLY INSTRUCTIONS.

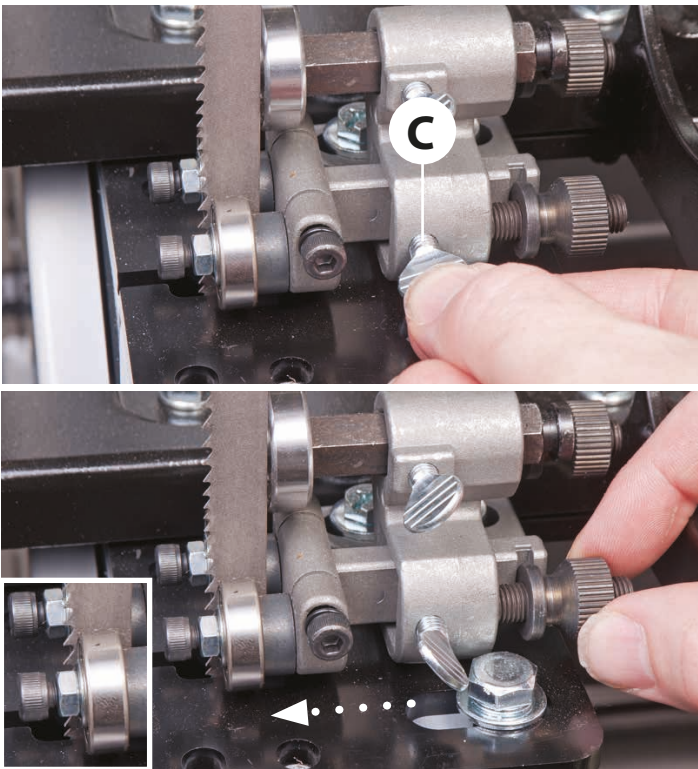
Remove the guide bearing guards and place safely aside, see fig 75. Beneath the table loosen the butterfly screw (C) holding the lower blade guide assembly in place and position so that the leading edges of the side guide bearings are approximately 2mm behind the gullets of the saw blade. Re-tighten the butterfly screw (C), see fig 76-77.

Note: The guide bearing should always be set behind the teeth of the saw.

Fig 75

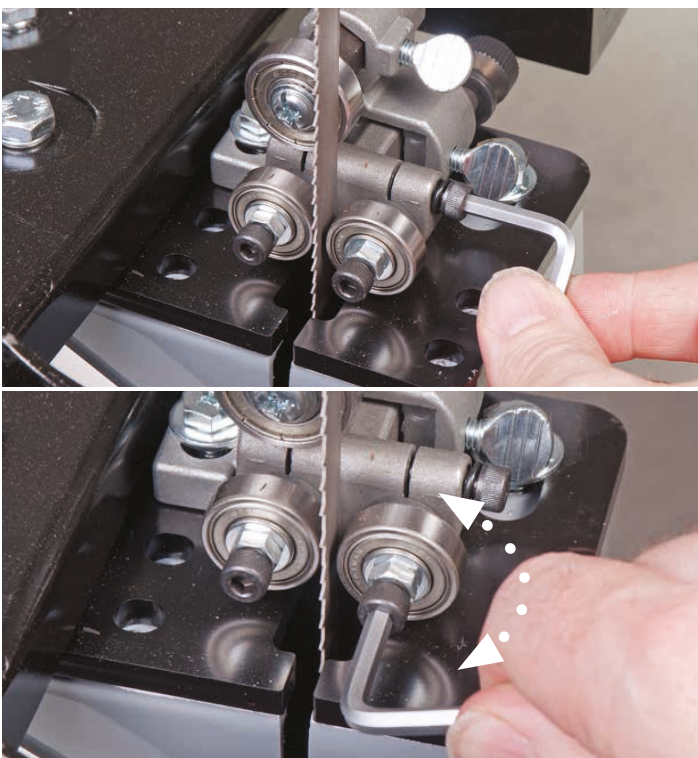


Fig 76-77



Rotate the top wheel by hand, at this point. None of the bearings should come into contact with the blade—only when in use. Adjust the lower blade guides, and set them similarly to the upper guides, using a Hex key to release and tighten the Hex screws, see figs 78-79.

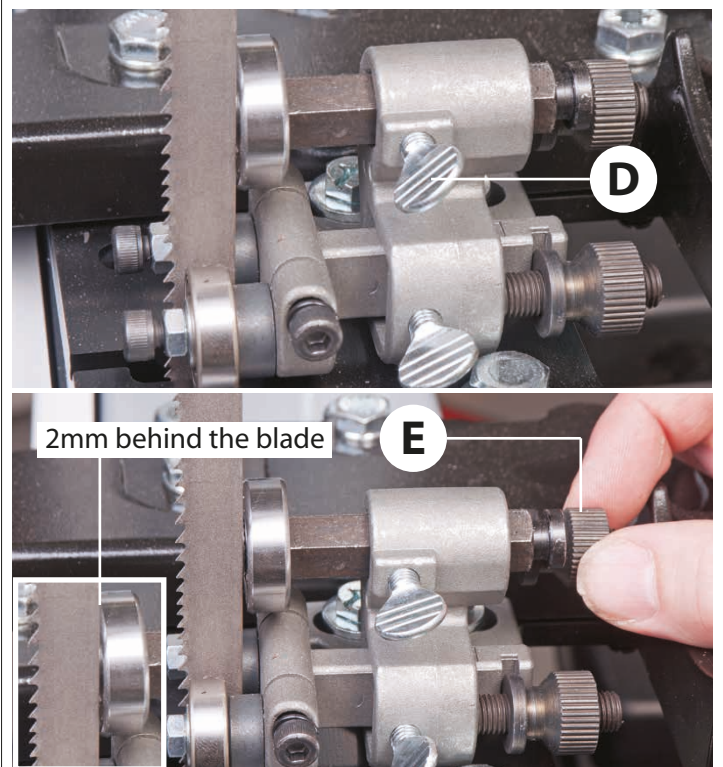
Fig 78-79



To adjust the lower thrust bearing, loosen the butterfly screw (**D**), see fig 80, turn the adjusting knob (**E**) to move the thrust bearing approximately 1mm behind the blade, see fig 82. Re-tighten the butterfly screw (**D**).

When all adjustments have been made, recheck that when the blade is pressed back against the thrust bearing, both the upper and lower side guides are still behind the teeth of the saw. Replace the guide bearing guards you removed earlier, see fig 75 and replace the cast iron table.

Fig 81-82



When all adjustments are complete re-connect the power, switch the saw on, allow to run for several minutes, check that the blade is still tracking correctly, there is no excessive vibration, etc. Switch off. **The saw is ready to be used.**

Operating Instructions

1. Make sure you have read and fully understood the general instructions and safety precautions in the preceding pages of this manual.
 2. Before connecting the machine to the supply; check the machine for obvious signs of damage, paying particular attention to the plug and the power cable. Check that the blade you are using is the correct one for the job in hand. Change the blade if necessary. Check the blade is not damaged; is clean, sharp, tracks properly and is correctly tensioned.
 3. Set the upper blade guide to approximately 12mm (1/2") above the height of the work piece.
 4. Check there are no foreign objects e.g. old nails, screws, small stones etc embedded in the material you are about to cut.
 5. Remove all accessories, tools etc., that have been used to set the machine.
 6. Ensure the machine is switched off. Plug the power cable into a correctly rated switched socket outlet. If extension leads are being used, check these for damage, do not use if damaged. Switch on. Allow the saw to run up to speed.
 7. Make sure that the material you are about to cut is within the machine's capacity, and the cut you are about to make is within the blades' capabilities, e.g. do not try to cut a 1" radius curve using a 5/8" blade.
 8. Make sure the blade is not in contact with the material when you start the saw. Do not try to cut too quickly; the correct cutting speed, would never see the blade pushed back against the thrust bearing, the saw would cut and clear the saw line at the rate the work piece was fed into it. If you notice that you require more and more pressure to effect the cut, chances are the blade is becoming blunt. Check and change if necessary.
 9. **DO NOT** let go of the work piece, if you have to change your grip, make sure one hand is holding the material at all times.
 10. If you are cutting long pieces of material think about sawing cutouts (i.e. a saw cut from the edge of the material to the saw line) along the saw line so that you can discard the off cuts as you progress down the saw line.
 11. Observe the old woodworkers' adage of never allowing your hand/fingers within one handbreadth of the blade.
 12. If you have to cut very small pieces of material, use a push stick.
 13. Remember to check the blade tension after a new blade has been 'working' for 30-60 mins. The blade will 'stretch' slightly when new.
 14. **DO NOT** release the tension on the saw blade when work is complete. The blades and the main saw frame do not respond kindly to constant changes in stress and tension. Only release the tension to change the blade or once work has finished for the day.
- The blade in tension over a long period of non-use will cause the tyres to develop 'flat' spots.



**WARNING! IF THE SAW JAMS!
SWITCH OFF IMMEDIATELY.**

Changing the Saw Blade

Put the table back to the level position if it has been tilted. Set the upper blade guide assembly approximately midway in the throat. Open the top and bottom covering doors and remove the table insert.

Remove the table stabilising bolt, release the blade tension by pulling the quick release lever towards you, see fig 83, the blade can be easily slipped off the wheels. Remove the blade carefully, 'wiggling' it clear of the upper blade guard and through the plastic lower blade guard

and out through the slot in the table. NOW is an excellent time to clean out the interior of the machine; remove the impacted 'crud' from the tyres, apply a little light oil to the screw threads of the blade and drive belt tensioners and the tracking control. The pivots and the slides of the top wheel mounting assembly and the captive stub axle of the drive belt tensioner in its slot could likewise be lightly oiled. If you are fitting a new blade, it will have been supplied to you "folded", bound together in this configuration with tape or tie wrap.

Fig 83



WARNING! BE VERY CAUTIOUS WHEN YOU 'UNFOLD' THE BLADE; IT TENDS TO 'SPRING' OPEN, BLADE AND TEETH GOING EVERYWHERE.

Also check that the blade did not “unfold” inside out. i.e. looking at the right side front of the loop, the teeth should be on the front of the blade and pointing down. If you can't arrive at this view, turn the blade inside out from its current position and look again.



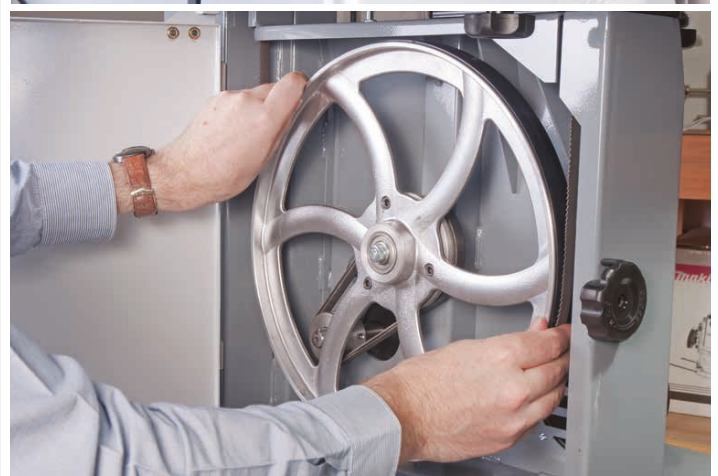
MAKE SURE THE BLADE TEETH ARE POINTING DOWN!

Open up all blade guides so that they are clear of the blade. Hold the blade approximately midway on either side of the loop and feed it into the table slot. When you get to the table insert cutout void, work the left side of the loop into the slot in the guard in the neck of the main saw frame. 'Wriggle' the right hand side of the blade through the slot in the lower bearing guide guards and through the guard on the upper blade guide assembly, see figs 84-85-86.

Fig 84



Fig 85-86



Ease the blade over the wheels and locate the blade in the blade guides. Check that the blade is sitting approximately in the middle of the wheels and re-tension the blade by pushing the quick release lever forward.

Turn the top wheel by hand to ensure the blade will not skip off the wheels and the blade is travelling in the blade guides. When you are sure that the blade is “ON” and stable, re-fit the table stabilising bolt and re-fit the table insert. Loosen the upper blade guide clamp and set the upper blade guide assembly so that the top of the blade guide is level with the centre of the top drive wheel, see fig 87. Re-tighten the clamp.

Now carry out the procedures as detailed in Setting up the saw.

Fig 87

Top of blade guide lined up with the centre of the upper wheel



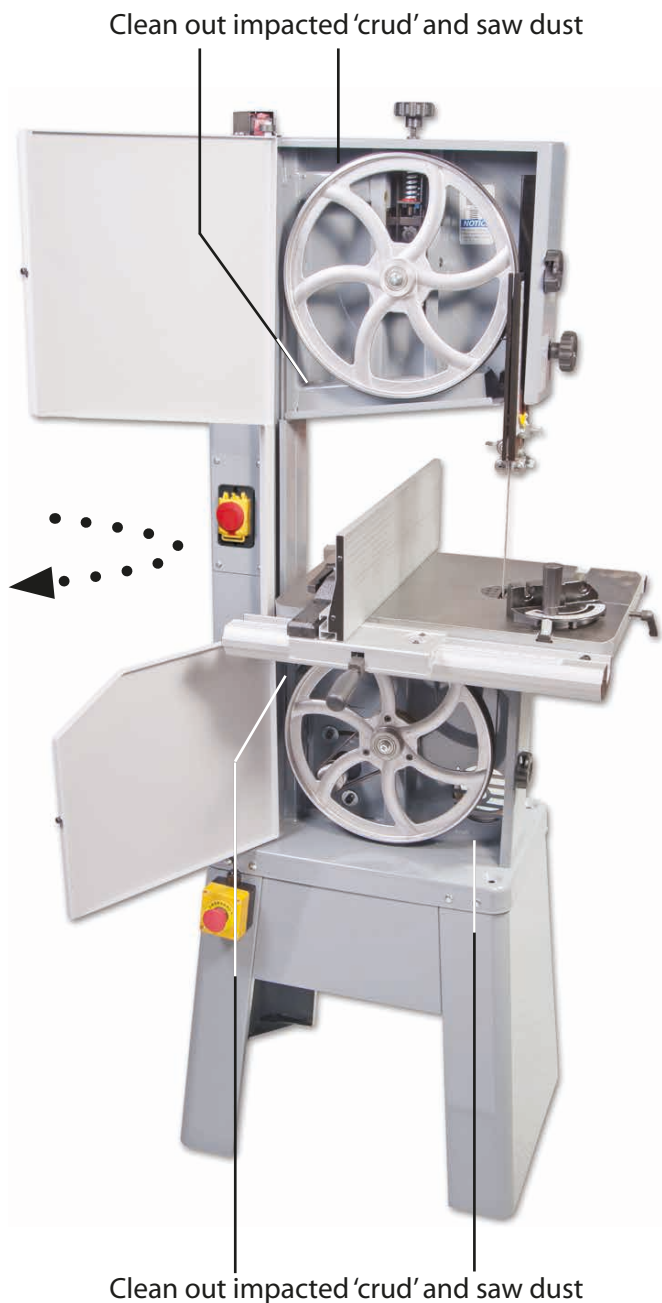
Maintenance

Daily

- Keep the machine clean.
- Check the saw blade for missing teeth and cracks, see fig 89.
- Spray oil the bare metal surfaces.

Weekly

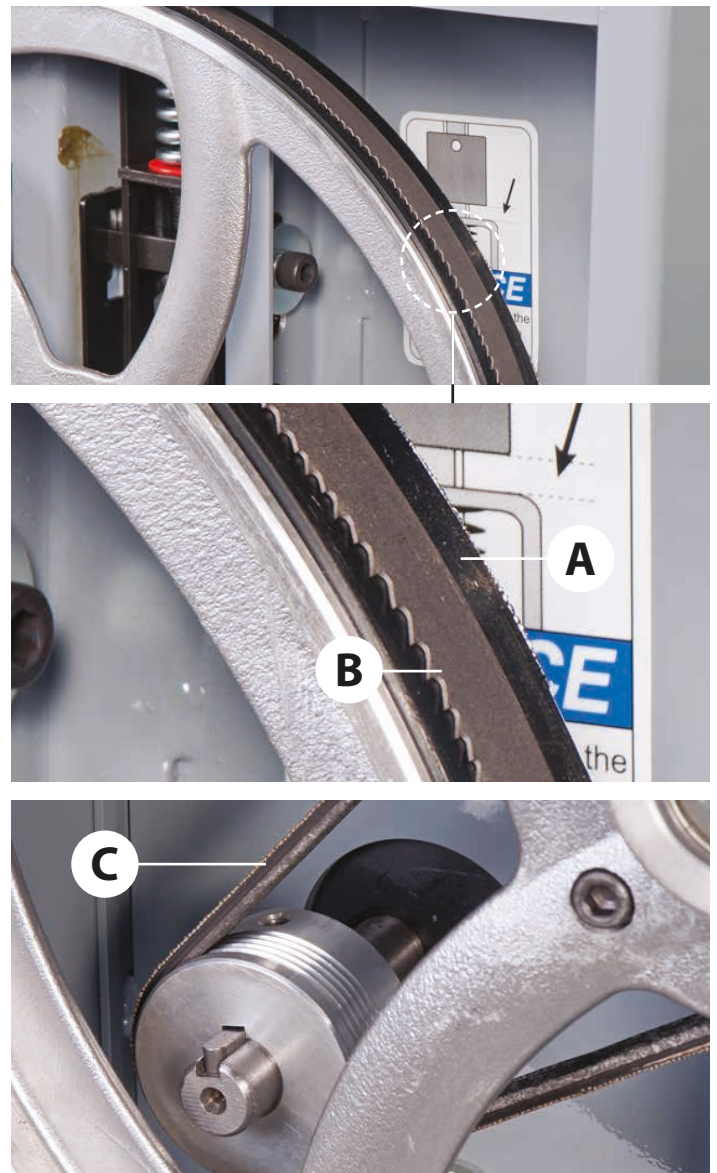
- Open the top and bottom wheel covers and clean out all saw dust.



Monthly

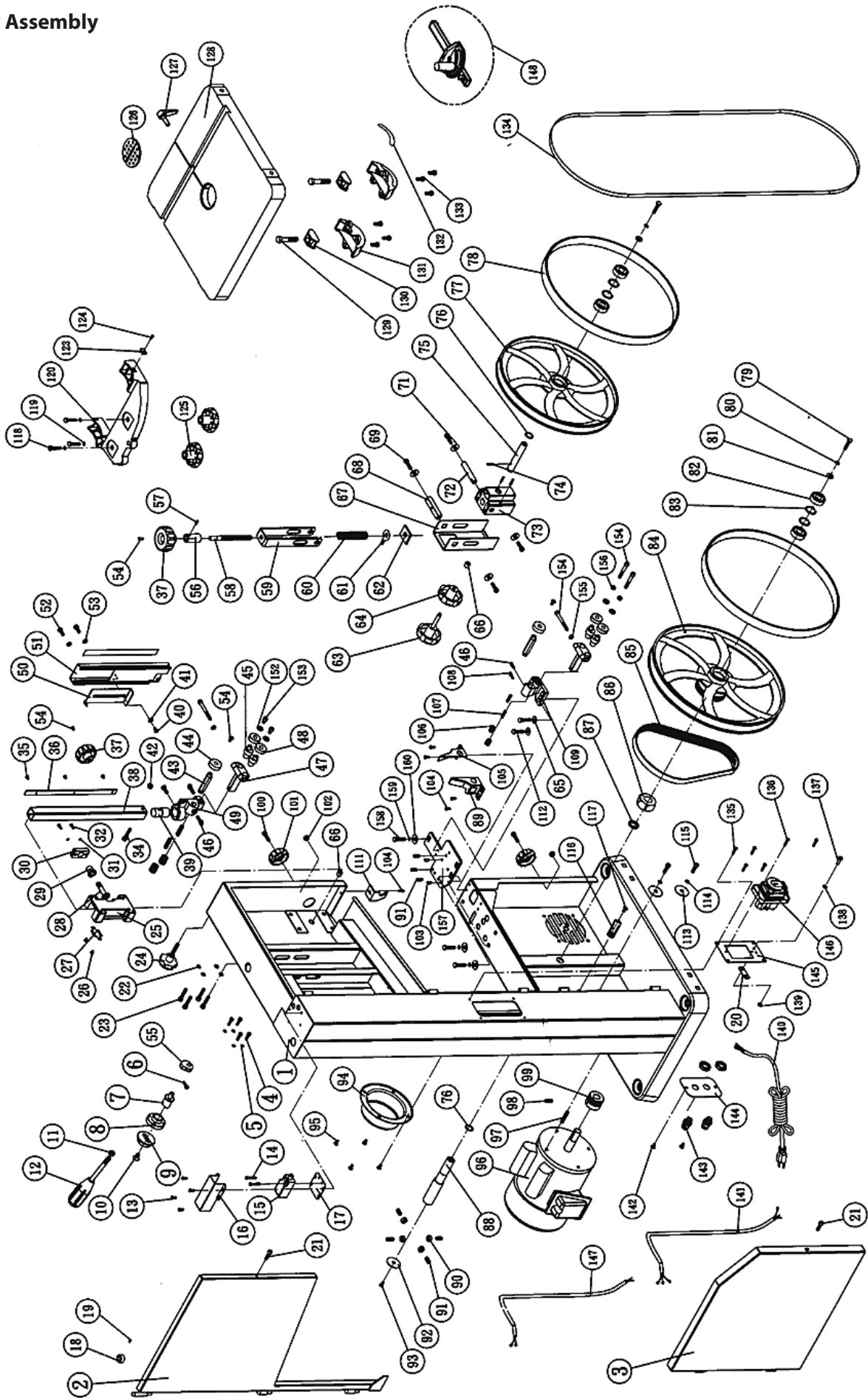
- Open the lower and upper door and check the condition of the tyres and the drive belt, see figs 88-89-90.
- Clean impacted 'crud' from the tyres, apply a little oil to the screw threads of the blade and drive belt tensioners. **DO NOT USE OIL** near the belt.
- The pivots and the slides of the top wheel mounting assembly and the captive stub axle of the belt tensioner in its slot could likewise be lightly oiled.
- Using an air line (**wearing goggles**) blow out the motor casing.

Fig 88-89-90



- Check the condition of the tyres (A)
- Check for missing teeth (B)
- Check the condition of the drive belt (C)

Main Saw Assembly



Exploded Diagrams/Lists

Key No.	Part No.	Description	Size	Qty
1	130051	BODY		1
2	130052	UPPER DOOR ASS'Y		1
3	130005	LOWER DOOR ASS'Y		1
4	SR069300	SOCKET CAP BOLT	M6x12	4
5	WS06000	SPRING WASHER	M6	4
6	SR59300	SOCKET CAP BOLT	M5x12	1
7	130017	BIAS SHAFT		1
8	130018	BIAS SHAFT CLAMP SEAT		1
9	130020	ADJUST SHOES		1
10	SM089400	SOCKET CAP BOLT	M8x16	1
11	NH081300	NUT	M8	1
12	130041	HANDLE		1
21	SR060200	SOCKET CAP BOLT	M6x10	2
22	WS080000	SPRING WASHER	M8	4
23	SJ080400	SOCKET CAP BOLT	M8X20	4
24	990656	LOCK KNOB	M8x20	1
25	130011	UPPER SUPPORT BRACKET POST		1
26	SN040100	COUNTERSUNK HEAD BOLT	M4x5	2
27	130032	SPRING PIECE		1
28	130012	ADJUST GEAR		1
29	135043	BUSHING		1
30	130016	GEAR FIXED		1
31	WS060000	SPRING WASHER	M6	2
32	SR069200	SOCKET CAP BOLT	M6x8	2
34	SR060600	SOCKET CAP BOLT	M6x30	1
35	SN040100	COUNTERSUNK HEAD BOLT	M4x5	3
36	130010	GEAR ROW		1
37	620029	ADJUST NUT		2
38	130009	GUIDE NUT		1
39	130025	CHANGE SHAFT		1
40	135073	STEP SCREW		1
41	135054	PLASTIC WASHER	M6	1
42	NH061000	NUT	M6	1
43	150015	SPACING SLEEVE		2
44	BB600002	BALL BEARING	6000ZZ	2
45	150213	BIAS SHAFT		4
46	150013	THUMBSCREW	M6x16	3
47	150207	SUPPORT BRACKET		2
48	BB608002	BALL BEARING	608ZZ	4
49	141076	UPPER SUPPORT BRACKET POST		1
50	130031	FREE BOARD		1
51	130031	BLADE COVER		1
52	SH060200	HEX HEAD BOLT	M6x10	2
53	WF061310	FLATWASHER	M6xø13	2
54	SF069200	PAN HEAD BOLT W/FLANCE	M6x8	4
55	130033	CAM		1

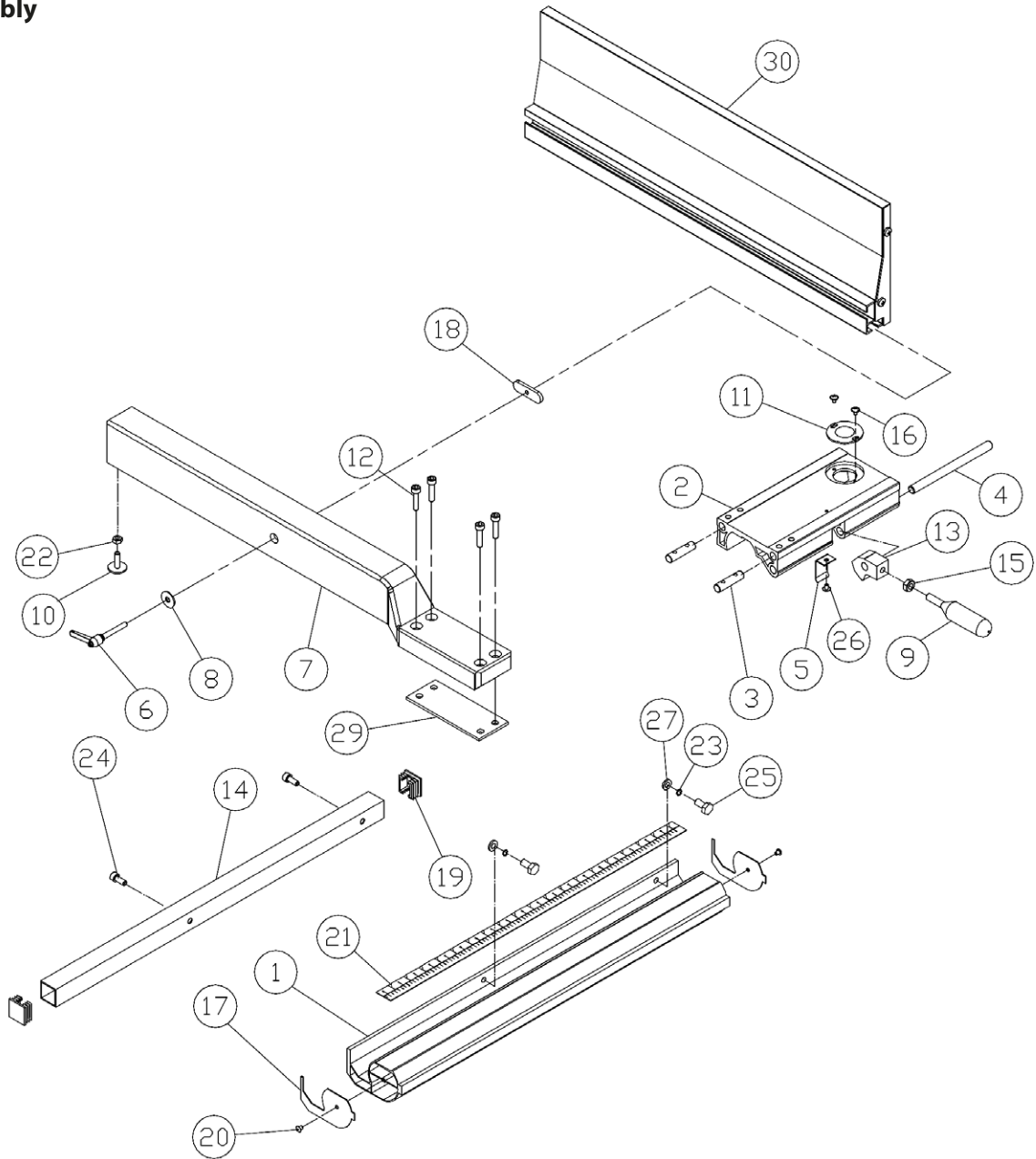
Exploded Diagrams/Lists

56	130044	FIXED RING		1
57	DD050100	SET SCREW	M5X5	1
58	130036	ADJUST SCREW		1
59	130022	SUPPORT SEAT		1
60	130048	SPRING		1
61	130023	INDICATOR		1
62	130019	FREE NUT		1
63	990655	LOCK KNOB	M8X45	1
64	990657	KNOB NUT		1
65	WF061310	FLATWASHER	M6x013	2
66	991608	PULL NUT	M8	2
67	130015	UPPER WHEEL FIXED SEAT		1
68	130028	FREE KEY	12x12	1
69	SR089400	SOCKET CAP BOLT	M8x 16	4
70	WS080000	SPRING WASHER	M8	4
71	WF082320	FLATWASHER	M8x023	4
72	130026	REVOLVING SPINDLE		1
73	130006	UPPER WHEEL JUMP SEAT		1
74	PS053000	SPRING PIN	05x30	3
75	130007	UPPER WHEEL SHAFT		1
76	WW152203	WAVES WASHER	015x022	2
77	170006	UPPER WHEEL		1
78	100025	WHEEL TYRE		2
79	SH089400	HEX HEAD BOLT	M8x16	2
80	WS080000	SPRING WASHER	M8	2
81	WF081818	FLAT WASHER	M8X016	2
82	BB620201	BALL BEARING	6202ZZ	4
83	RR350000	RETAINING RING	R35	4
84	130035	LOWER WHEEL		1
85	LJ018550	V-BELT	185J5	1
86	NH182601	NUT	M18x1.5	1
87	Ws180000	SPRING WASHER	M18	1
88	132002	LOWER WHEEL SHAFT		1
89	130042	LEFT COVER		1
90	Nh081300	NUT		4
91	Ss080400	SET SCREW	M8x20	7
92	135013	COVER		1
93	Sf059200	PAN HEAD BOLT W/FLANGE	M5x8	1
94	412007	INLET		1
95	Sf060200	PAN HEAD BOLT W/FLANGE	M6x10	4
96	Mh130002	MOTOR	3/4HP 230V 50HZ	1
97	Kp050520	KEY	5x5x20	1
98	Ss060200	SET SCREW	M6x10	1
99	100148	MOTOR PULLEY		1
100	Sr080400	SOCKET CAP BOLT	M8x20	2
101	135041	KNOB		2
102	Ny061000	NYLON NUT		2

Exploded Diagrams/Lists

103	150031	PIN		2
104	Sf059200	PAN HEAD BOLT W/FLANGE	M5x8	5
105	130043	RIGHT COVER		1
106	150010	ADJUSTING NUT		4
107	Ss080801	ADJUSTING SCREW	M8x1.0x40	4
108	150014	THUMBSCREW	M6x12	1
109	150206	LOWER SUPPORT BRACKET POST		1
111	135011	POINT		1
112	Sh069300	HEX HEAD BOLT	M6x12	2
113	Wf083030	FLAT WASHER	M8xO30	2
114	Ws080000	SPRING WASHER	M8	2
115	Sr080500	SOCKET CAP BOLT	M8x25	2
116	170507	BRUSH		1
117	Sf059200	PAN HEAD BOLT W/FLANGE	M5x8	1
118	Sh080600	HEX HEAD BOLT	M8x30	3
119	Ws080000	HEX HEAD WASHER	M8	3
120	130021	TRUNNION SUPPORT BRACKET		1
121	Sh081600	HEX HEAD BOLT	M8x80	1
122	Nh081300	NUT	M8	1
123	110049	POINTER		1
124	Sp059100	PAN HEAD BOLT	M5x6	1
125	100030	LOCK KNOB	M10	2
126	199037	TABLE INSERT		1
127	130045	TABLE PIN		1
128	170749	TABLE		1
129	Sh101003	HEX HEAD BOLT	M10x50	2
130	100041	TRUNNION CLAMPSHOES		2
131	100042	TRUNNION		2
132	100051	SCALE		1
133	Sg069300	HEX HEAD FLANGE BOLT	M6x12	6
134	130024	SAW BLADE	2553 x 10x0.5mm	1
135	Sf059200	PAN HEAD BOLT W/FLANGE	M5x8	4
136	Sp040200	PAN HEAD BOLT	M4x10	2
137	Sp059300	PAN HEAD BOLT	M5x12	2
138	We050000	STAR WASHER (EXTERNAL)	M5	2
139	Nh050800	NUT	M5	4
140	Ic130003	POWER CORD		1
141	Im130002	MOTOR CORD		1
142	Sf059200	PAN HEAD BOLT W/FLANGE	M5x8	2
143	998621	STRAIN RELIEF		2
144	135056	PLATE		1
145	130013	SWITCH PLATE		1
146	994542	SWITCH		1
148	Ab100083	MITER GAUGE (ASM)		1
	100083	MITER GAUGE		1

Fence Assembly

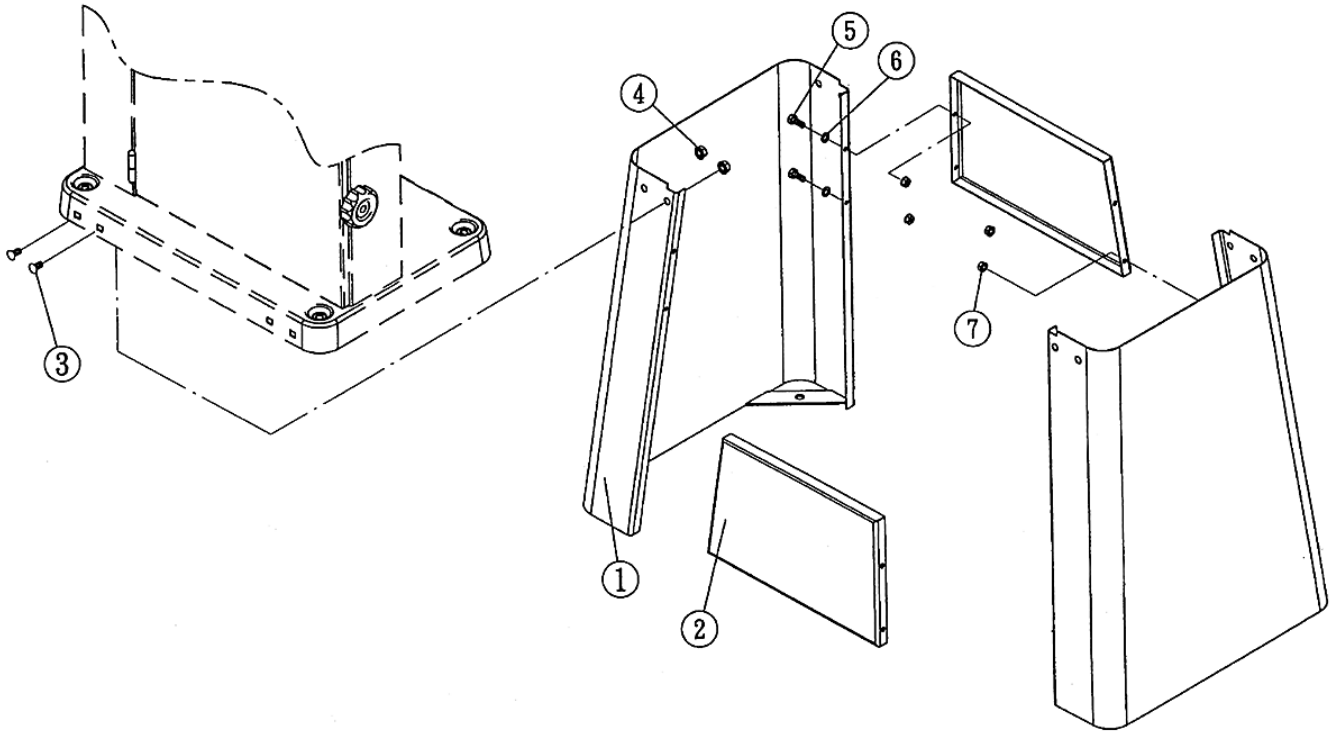


No	Part No	Description	Size	Qty
01	198018	FIXED BASE	640	1
02	198002	ADJUST BASE		1
03	198003	FIXED SHAFT		2
04	198005	SHAFT		1
05	198006	SPRING WASHER		1
06	198074	LOCK KNOB	M8x44	1
07	198077	SUPPORT TUBE	590	1
08	WE082320	FLAT WASHER	M8xε23	1
09	198013	HANDLE		1
10	198012	ADJUST SCREW		1
11	198007	CONVEX		1
12	SR060500	HEX SOCKET BOLT	M6x25	4
13	198004	FIXED LUMP		1
14	198020	SQUARE TUBE	640	1
15	NH081300	NUT	M8	1

16	SE049100	PAN HEAD BOLR W/ FLANGE	M4x6	2
17	198014	GUARD PIECE		2
18	200527	MOVING PLATE		1
19	198016	PLUGGED		2
20	ST039300	TAPPING SCREW	M3.5x12	2
21	LM000539	SCALE		1
22	NH061000	NUT	M6	1
23	WS060000	SPRING WASHER	M6	2
24	SR069400	HEX SOCKET BOLT	M6x16	2
25	SH060400	HEX HEAD BEILT	M6x20	2
26	SF049200	PAN HEAD BEER W/ FLANGE	M4x8	1
27	WE061310	FLAT WASHER	M6x13	2
29	198008	BRACKET	T=3	1
30	AC198082	FENCE	590	1

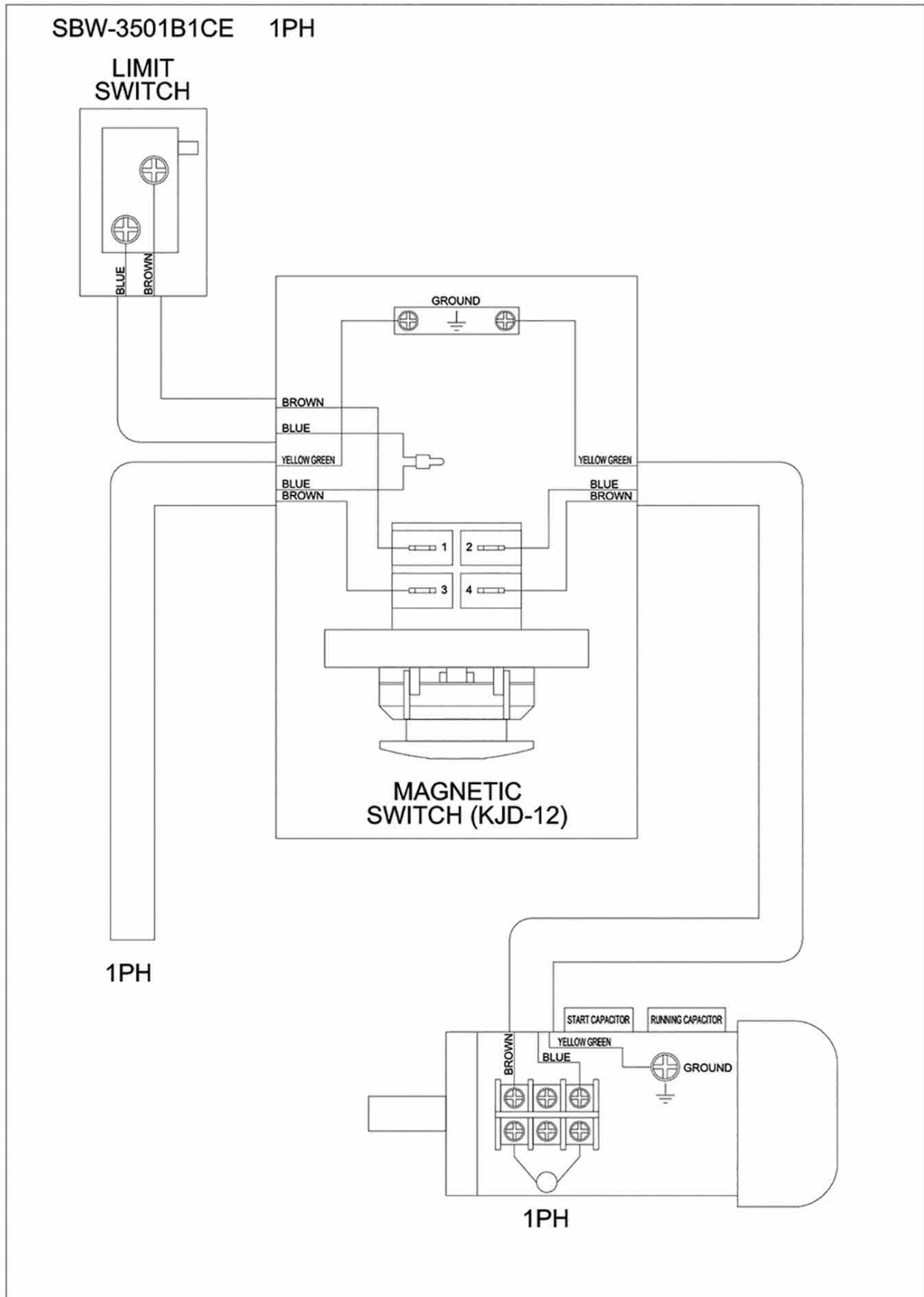
Exploded Diagrams/Lists

Stand Assembly



Key No.	Part No.	Description	Size	Qty
1	100144	STAND		2
2	100164	SIDE COVER		2
3	SC089400	COACH BOLT	M8x16	8
4	NF081300	NUT	M8	8
5	SH069400	HEX HEAD BOLT	M6x16	8
6	WF061310	FLAT WASHER	M6xø13	8
7	NF061000	NUT	M6	8

SWITCH (KJD-12)



The **Axminster guarantee** is available on Craft, Trade, Engineer, Air Tools & CNC Technology Series machines

Buy with confidence from Axminster!

So sure are we of the quality, we cover all parts and labour free of charge for three years!



For more information visit axminster.co.uk/3years



The packaging is suitable for recycling.
Please dispose of it in a responsible manner.



EU Countries Only

Do not dispose of electric tools together with household waste material.
By law they must be collected and recycled separately.

AXMINSTER
Tools & Machinery

Axminster Tools & Machinery Ltd
Axminster Devon EX13 5PH

axminster.co.uk